



**SBU – Industrial Packaging,
5, J. N. Heredia Marg, Ballard Estate,
Mumbai- 400001, India
Tel. No. 091 - 022 –66258208/66258209
Fax No. 091 - 022– 66258200**

NOTICE INVITING TENDER

Tender No. 0100LM1601 dated 09.03.2020

**Due date of Tender : 19.03.2020 at 15:00 hrs.
Opening of Price Bid: 19.03.2020 at 15:30 hrs.**

Sealed Single Bid offers are invited for supply of “Scissors Arm {Upper & Lower} & Bushes” for our plant at Taloja (Navi Mumbai). The tender document can be downloaded from www.balmerlawrie.com website.

Contact details

Balmer Lawrie & Co.Ltd.
SBU-Industrial Packaging,
5, J. N. Heredia Marg , Ballard Estate
Mumbai – 400 001.

Contact Persons:

Shri Tushar Ingale, Mob.9769015541 Land Line No.022 66258209
e.mail: ingale.td@balmerlawrie.com

Smt Amanda Couto – Mob-09004002269, 022 66258208,
email ID: amanda.c@balmerlawrie.com

Introduction

Balmer Lawrie & Co. Ltd under the Ministry of Petroleum & Natural Gas is a Government of India Enterprise with its corporate office at 21, Netaji Subhas Road, Kolkata-700 001. Industrial Packaging is a Strategic Business Unit of the company manufacturing steel drums.

A. Instructions for bidders

1. **Please Refer to Annexure –III for detailed Scope of supply.**
2. The tender is invited in **Single Bid System**. The tender document consists of **Price Bid**.
3. All documents required in the tender can be deposited in the Tender Box at the following address, "Balmer Lawrie & Co. Ltd. 5, J. N. Heredia Marg, Ballard Estate, Mumbai-400 001"
4. Important points to be noted

4.1 Due date for submission of bids 19.03.2020 at 15:00 hrs.

4.2 Price Bid opening on 19.03.2020 at 15:30 hrs.

All Bids are to be completed and returned in accordance with tender requirements within the duration as mentioned.

The term **"BL"** wherever mentioned in the tender document refers to **"Balmer Lawrie & Co. Ltd."**

BL would be the Purchaser/Owner for the tendered item.

The successful bidder will be the Supplier.

This document is the Tender.

The Acceptance of the Order by the successful bidder will form the contract.

Response from BL registered Vendors alone will be accepted and that other interested Vendors may seek to register with the unit and subject to such registration being confirmed, they would be considered for subsequent Tenders.

5. Corrigendum to tender:

The bidder has to keep track of any changes by viewing the addendum / Corrigendum's issued by the Tender Inviting Authority on time-to-time basis in the E-Procurement platform/ newspapers. The Company calling for tenders shall not be responsible for any claims/problems arising out of this.

6. Format of Tender Document

Tender Documents consist of:

- A. Instruction for bidders
- B. Special Terms & Conditions

- C. General Terms & Conditions
- D. Annexure I – GST Compliances
- E. Annexures II – Details of Vendors
- F. Annexure III – Scope of supply
- G. Annexure IV – Price Bid
- H. Annexure V – Addresses of Balmer Lawrie location
- I. Annexure VI - Bank Details for SWIFT/RTGS Transfers
- J. Annexure VII- Code of Conduct for Balmer Lawrie & Co. Suppliers
- K. Annexure VIII – CPPP Declaration
- L. Annexure IX – List of Designated Officers responsible for releasing payment

The bidder is expected to examine the Tender documents, including all instructions, forms, General Terms & Conditions, Special Terms & Conditions, Technical Specifications and other documents and to fully familiarize itself with the requirements of the bidding documents. Failure to furnish all the information required by the Bidding Documents or the submission of a bid not substantially responsive to the Bidding Documents in every respect may result in the rejection of the Bid.

7. Late Bids

No offers will be entertained after the closing date.

8. Bid Validity

The offer shall remain valid for a period of **three months** from the date of opening of the Price Bid.

9. Bid Rejection Criteria

A bid may be rejected if

- i. If the bidder does not submit the supporting documents specified.
- ii. The deviations from the terms mentioned in the document affects in any way the scope, quality and performance.
- iii. Conflict of interest between the bidder and the Company is detected at any stage.
- iv. Bidders not registered under GST are not eligible for participating in this tender. Bidders to mandatorily provide the Provisional GST Number as per Annexure- II and also provide proof of such registration. Offers received from bidders who are not registered under GST, will not be considered for any evaluation against this tender.
- v. Bidders who are having unresolved issues, disputes, complaints, legal or court cases against the company and bidders with whom Balmer Lawrie have/had any dispute during the last 5 years whether the same has/had been subsequently settled or not, will not be eligible to participate/bid in the tender.

10. Clarifications

Clarifications that the Bidder needs to have on the tender specification can be sought from BL in writing within one week from the date of issue of this enquiry.
All clarifications shall be by e-mail (*Only email queries shall be replied*)

11. Opening of Price Bid

The price bids of bidders with valid offers as set by BL shall only be opened.

12. Complete Scope of Supply

The complete scope of supply has been defined in Annexure III of the tender document.

13. Tender Documents and Deviations

It is expected that bidders will submit bids based strictly on the terms and conditions and specifications contained in the bidding documents and will not stipulate any deviations. Deviation from Scope of supply, as given in the tender document Annexure-III would invite immediate disqualification from further consideration of the bid.

14. Language of Bids

The Bid prepared by the bidder, all documents attached to and/or relating to the bid and all correspondence exchanged by the Bidder and BL shall be written in English language only.

Any printed literature furnished by the bidder may be written in any other language **provided that this literature is accompanied by an authenticated English translation, in which case, for purpose of interpreting the Bid, the English translation shall govern.**

15. Preparation and submission of Tender Documents

The bidders are required to fill the tender document in a format as outlined therein.

a. Price Bid (Annexure IV is Price Bid)

The lowest bidder will be decided based on Composite Lowest Nett delivered price (NDP) in Indian Rupee, for the items mentioned in the scope of supply. In case there is a tie between bidders at L1 position, these bidders will have to submit discount in a sealed envelope. Thereafter the L1 position will be decided.

The Price bid should not contain any information other than the price. The price is to be mentioned in both Figures and words and where there is a difference between the two, rate given in words will be taken as authentic.

Price bid should be filled in the format provided (Annexure IV).

Negotiations, if held, will be only with the lowest bidder.

b. The bidders are requested to submit the Price Bid to the Tender Inviting Authority before the due date at our Ballard Estate Office at The Basement of 5, J N Heredia Marg, Ballard Estate, Mumbai – 400 001.

B. SPECIAL TERMS & CONDITIONS**1. Security Deposit (SD)**

Security Deposit amount of 5% of the basic order value to be deposited by the successful Bidder in the form of Pay order / Demand Draft in favour of Balmer Lawrie & Co. Ltd, payable at Mumbai. (Ballard Estate Office,5 J.N.Heredia Marg,Mumbai-400 001.

The Security Deposit to be submitted within 10 days of receipt of the Purchase Order. **Security Deposit can also be made directly to our Standard Chartered Bank (Account No. 222-0-526803-6, NEFT Code - IFSC "SCBL0036046) through electronic transfer and proof of transfer of funds deposited with us.**

Cheque/Cash or any other forms of payment are not acceptable towards Security Deposit.

- The Security Deposit will not bear any interest and shall be refunded to successful bidder, only on successful delivery of the tendered item.
- All sums of compensation or other sums of money as determined, if any, payable by the bidder may be deducted from the Security Deposit.

Security Deposit is liable for forfeiture, if

- (a) Non supply after Acceptance of Purchase Order.
- (b) Successful Bidder fails to deliver the item as per the terms & condition of the Purchase Order.
- (c) Successful bidder violates the tender condition,
- (d) If the performance of the bidder is found to be unsatisfactory.
- (e) Security Deposit will be refunded only after successful completion of the contract.

2. Payment Terms:

Our payment terms are as follows:

Payment for the accepted material will be made within 30 days from the date of receipt of the material or bill whichever is later. Payments for supply shall be made from the delivery location.

Payments for supply to different locations shall be made from the respective location, [Refer Annexure IX for designated officers responsible for releasing payment.

- 3. Bidders not registered under GST are not eligible for participating in this tender. Registered bidders to mandatorily provide the provisional GST Number as per Annexure II and also provide proof of such registration. Offers received from bidders who are not registered under GST, will not be considered for any evaluation against this tender.**

4. Risk Purchase

In case delivery of material is not effected as per given schedule from time to time, we reserve the right to prune the order quantity to the extent it is purchased from the market at your cost and risk. The deduction on account of such procurement, if any, will be recovered from your due payments / security deposit.

5. Delivery Period :

Within 3-4 weeks from the date of our Purchase Order.

6. Testing / Inspection

Sampling, testing and acceptance of the material supplied shall be carried out in accordance with the procedure prescribed by the company.

7. Delivery Of “Bushes & Arms”

- i) To our plant at Taloja [Navi Mumbai] (address given in Annexure V). Delivery schedule should be adhered to strictly. The supplier shall complete the supplies of ordered quantities within the stipulated period.
- ii) The item should be packed to withstand the hazards normally encountered with the means of transport, including loading and unloading operation. The material should be suitably protected from water ingress especially during monsoon. The successful bidder shall be held liable for all damages to the item due to defective or insufficient packaging.
- iii) All costs related to unloading & stacking of material at the plant shall be at the supplier's account.

8. Transit Risk Insurance

Transit Risk Insurance shall be covered by the bidder from the successful bidder's stock point to BL's plants.

Any failure by the bidder to do so shall place the consignment at the bidder's risk.

C. GENERAL TERMS AND CONDITIONS**1. Introduction**

The bidder means the firm or company with whom the order is placed and shall be deemed to include the bidder, successors, representatives, heirs, executors and administrators.

Whenever there is a duplication of clause in the terms and conditions, the clause which is beneficial to BL will be considered applicable at the time of any dispute.

2. Scope of Supply

Scope of Supply for the tender shall be as mentioned in Annexure III.

3. Reference for Documentation

Purchase Order Number must appear on all correspondence, drawings, invoices, packing and on any documents or papers connected with the order.

4. Confirmation of Order

The successful bidder shall acknowledge the receipt of purchase order within 10 days following the mailing of this order in writing or through email and shall thereby confirm his acceptance of purchase order in entirety without exceptions

5. Relaxation of Tender Terms & Conditions

BL reserves the right to relax any of the tender conditions, if necessary, while finalizing the tender at its discretion.

6. Rejection of Bids

The bid of any bidder may be rejected if a conflict of interest between the bidder and BL is detected at any state. BL reserves the right to accept any tender in whole or in part and reject any or all tenders without assigning any reason. The decision of BL in this connection will be final.

7. Delays**7.1 Delay in Bidding**

Late tenders / delayed tenders including postal delay and those not conforming to the prescribed terms and conditions will not be considered.

7.2 Delay in Delivery

The bidder shall try to complete the delivery as mentioned in the scope of supply within the stipulated time. Delays in delivery or completion will attract Risk Purchase as mentioned in Special Terms & Conditions Clause no.4.

8. Delay due to Force Majeure

In the event of causes of force Majeure occurring within the agreed delivery terms, the delivery dates can be extended by the tenderer on receipt of application from the bidder within stipulated delivery period. Only those causes that depend on natural calamities, civil wars, national strikes and strikes /lockout at Bidder's works which have duration of more than seven consecutive calendar days are considered the causes of Force Majeure. The bidder must advise BL by a registered letter duly certified by local chamber of commerce or statutory authorities, the beginning and end of cause of delay immediately, but in no case later than 10 days from the beginning and end of such cause of Force majeure condition as defined above.

BL reserves the right to ask Bidder to suspend despatches of goods/materials covered by this order for such period as they may think fit in the event of strikes, accidents or other causes beyond BL's control.

9. Sub-Contracts

The successful bidder shall not assign the Contract in whole or part without obtaining the prior written consent of BL. The bidder shall, notwithstanding the consent and assignment, remain jointly and severally liable and responsible to BL together with the assignee, for and in respect of the due performance of the contract and the bidder's obligations there under.

10. Control Regulations

Successful bidder warrants that all goods/materials covered by this order have been produced, sold, despatched, delivered and furnished in strict compliance with all applicable laws regulations, labour agreement, working conditions and technical codes and statutory requirements as applicable from time to time. All laws and regulations required to be incorporated in executing this tender are hereby deemed to be incorporated by this reference. Owner can disown any responsibility for any irregularity or contravention of any of the statutory regulations in the manufacture or supply of goods covered in the order. The Bidder shall ensure compliance with the above and shall indemnify tenderer against any actions, damages, costs and expenses of any failure to comply as aforesaid.

11. Termination

Without prejudice to BL's right to price adjustment by way of discount or any other right or remedy available to BL, BL may terminate the Contract of any part thereof by a written notice to the bidder if :

- i. The bidder fails to comply with any material term of the Contract.
- ii. The bidder informs BL of its inability to deliver the item or any part thereof within the stipulated Delivery Period or such inability otherwise becomes apparent.
- iii. The bidder fails to deliver the item within the stipulated Delivery Period and/or to replace any rejected or defective item promptly.
- iv. The bidder becomes bankrupt or goes into liquidation.
- v. The bidder makes a general assignment for the benefit of creditors.
- vi. A receiver is appointed for any substantial property owned by the bidder.
- vii. The bidder has misrepresented to BL, acting on which misrepresentation, BL has placed the Purchase Order on the bidder.

Upon receipt of said termination notice, the bidder shall immediately stop supply.

On termination of the contract, without prejudice to any other right or remedy available to BL under the contract, in the event of BL suffering any loss on account of delayed delivery or non-delivery, BL reserves the right to claim and recover damages from the bidder in respect thereof. The Security Deposit will be forfeited

12. Arbitration

Any dispute or difference arising under this Contract shall be referred under jurisdiction of **Kolkata** to a sole arbitrator to be appointed by the Chairman & Managing Director, Balmer Lawrie & Co. Limited and the provisions of Arbitration Act, 1996 including any statutory modifications or enactment thereof shall apply to the Arbitration proceedings. The fees of the arbitrator, if any, shall be shared equally by both the parties. The award shall be a speaking award stating reason therefor and is final & binding on the parties. The proceeding shall be conducted in English language and courts at **Kolkata** will have exclusive jurisdiction to settle any dispute arising out of this contract

In event of any dispute or difference relating to the interpretation and application of the provision of commercial contract(s) between Central Public Sector Enterprises (CPSEs) / Port Trusts inter se and also between CPSEs and Government Departments/Organizations (excluding disputes concerning Railways, Income Tax, Customs & Excise Departments), such disputes or difference shall be taken up by either party for resolution through AMRCD as mentioned in DPE OM no 4(1)/2013-DPE(GM)/FTS-1835 dated 22.05.2018

Company Seal	Signature	
	Name	
	Designation	
	Company	
	Date	

ANNEXURE I**D. GST Compliances**

- [1] Vendor to comply with all requirements under GST and provide their GST Registration details as per Annexure-II attached
- [2] Vendor to issue a valid invoice with correct and complete disclosures as required under GST invoice rules and payments shall be processed only post receipt of correct invoice from the vendor
- [3] Vendor has to provide clear indication of place of supply [Invoicing location] related to place of supplies [BL location].
- [4] Vendors are required to raise invoice as per the GST tax structure.
- [5] Vendors to ensure that all invoices submitted are compliant with GST Laws. Any discrepancies in the Invoice which results in tax credit loss to Balmer Lawrie will be recovered from vendors.
- [6] In case of advance payment against goods/services, vendor to ensure payment of tax as per GST Laws.
- [7] Vendor should compulsorily follow all the provisions of GST and in the event any default for fulfilling any provisions of the Act, BL would exercise the right for non-payment/withholding payment,/ black listing the vendor/debarring the vendor from participating in future tenders for a certain period [to be decided by BL].

Company Seal	Signature	
	Name	
	Designation	
	Company	
	Date	

E.DETAILS OF VENDOR**ANNEXURE-II**

	Name of the Vendor	
2	Address	
3	Postal Code	
4	State	
5	Country	
6	Telephone No.	
7	Mobile No.	
8	Fax No.	
9	Email ID	
10	Contact Person	
11	Bank Name	
12	Street	
13	City	
14	Branch Name	
15	IFSC Code	
16	MICR Code	
17	Account Number	
18	Minority Indicator	
19	GSTIN Registration Number	
20	HSN/SA Code for Supply/Service	
21	GST rates (in %) applicable for Supply/Service to be provided.	
22	Composition Scheme Applicable	Yes / No
23	Proof of GSTIN Registration No. per state [From GSTN website]	
24	Vendor's GSP name [GST Suvidha Provider's]	
25	Exemption No.	
26	Exemption Percentage	
27	Exemption Reason	
28	Exempt From	
29	Exempt To	

F. SCOPE OF SUPPLY

ANNEXURE-III

ANNEXURE - I

D. SCOPE OF SUPPLY

ITEM DESCRIPTION:

- [1] Set of Bushes of Scissors
Arm Assembly
Material EN9
Quantity ... 3 sets
- [2] Scissors Arm Upper
Material EN9

Quantity ... 3 nos
- [3] Scissors Arm Lower
Material EN9

Quantity ... 3 nos

[Refer attached drawings]

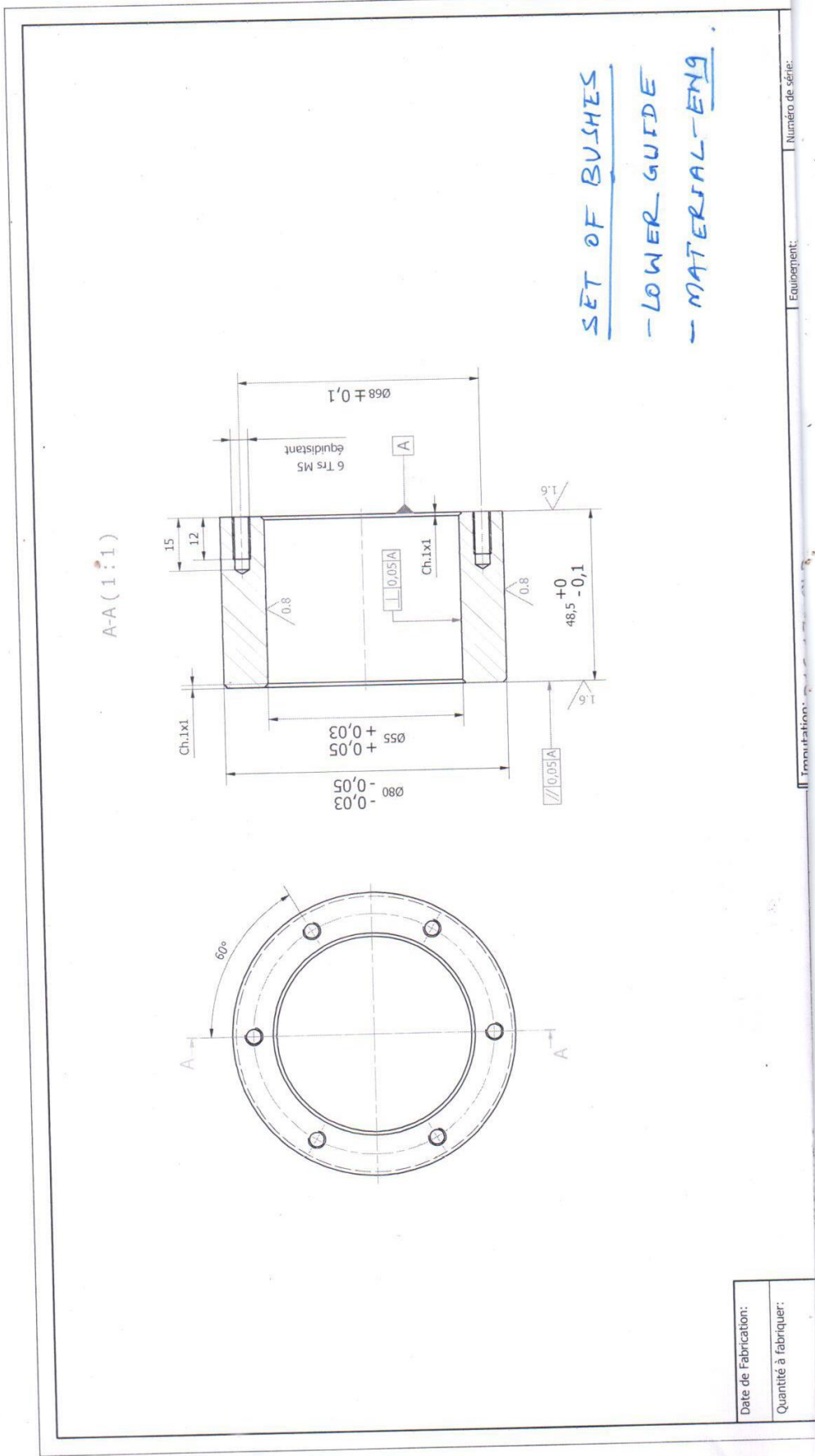

SET OF BUSHES
- LOWER GUIDE
- MATERIAL-ENG.

Date de Fabrication:
Quantité à fabriquer:

Immatriculation: _____ Equipement: _____ Numéro de série: _____

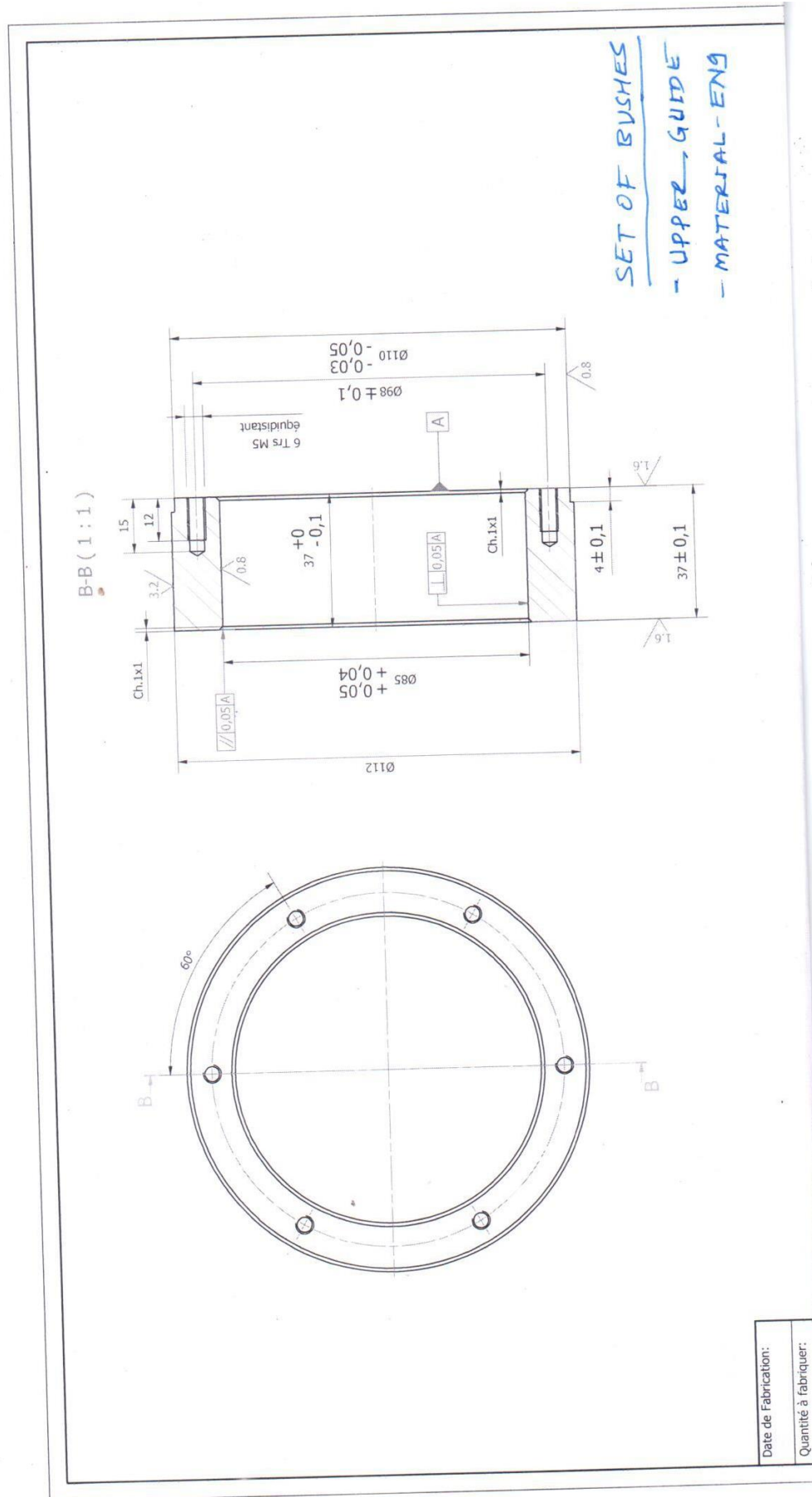

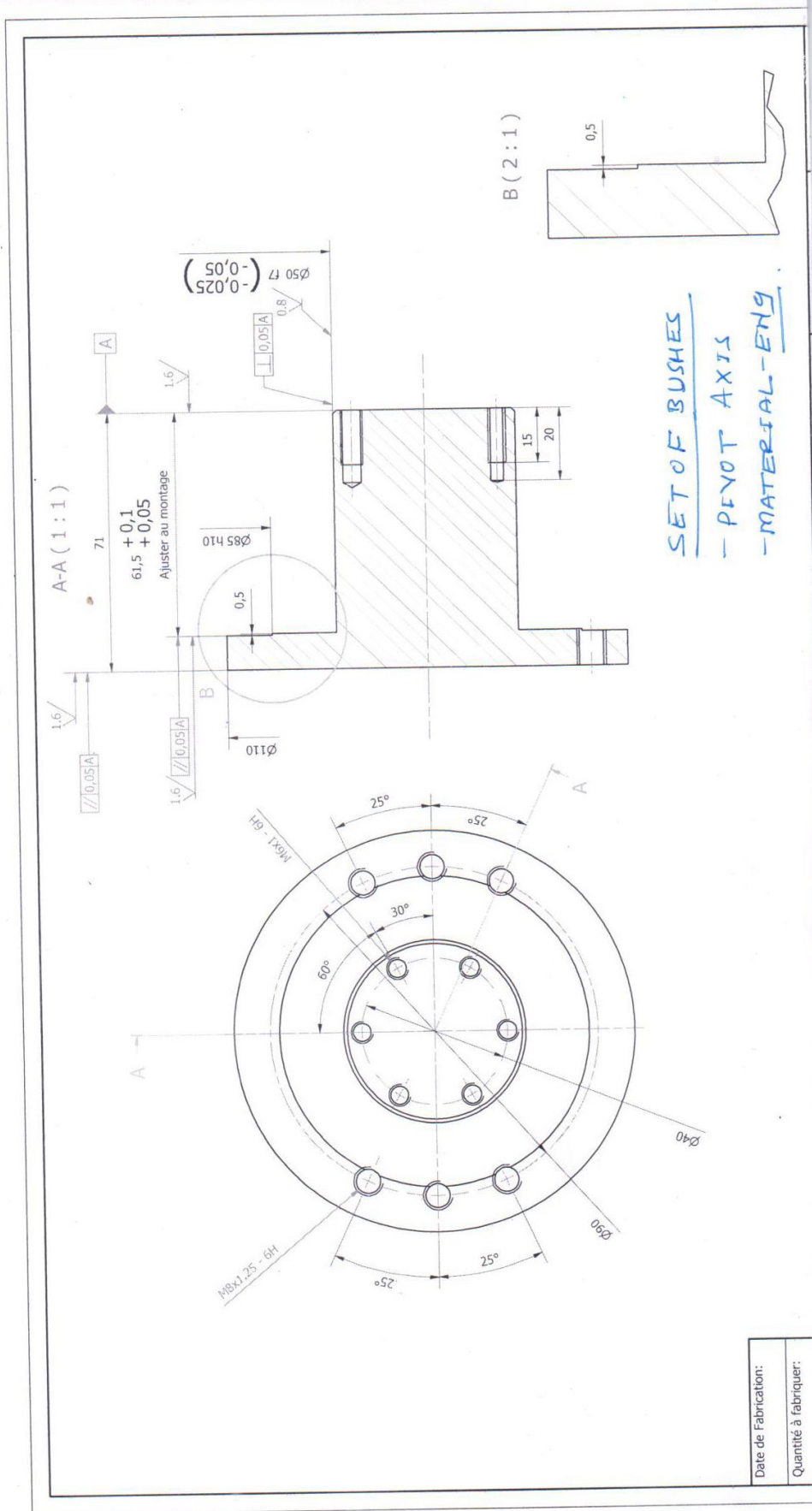

Date de Fabrication:
Quantité à fabriquer:

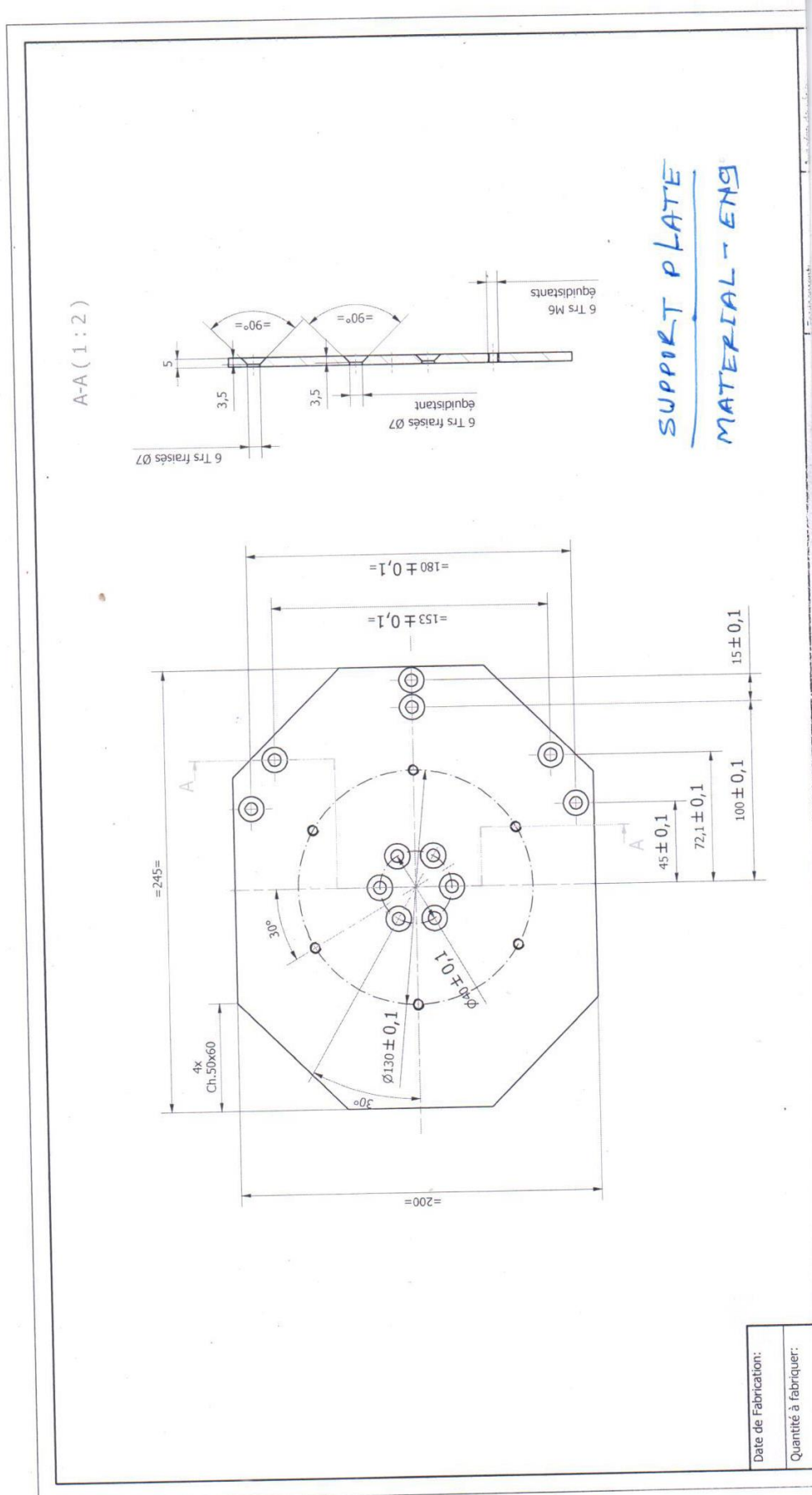

Date de Fabrication:
Quantité à fabriquer:

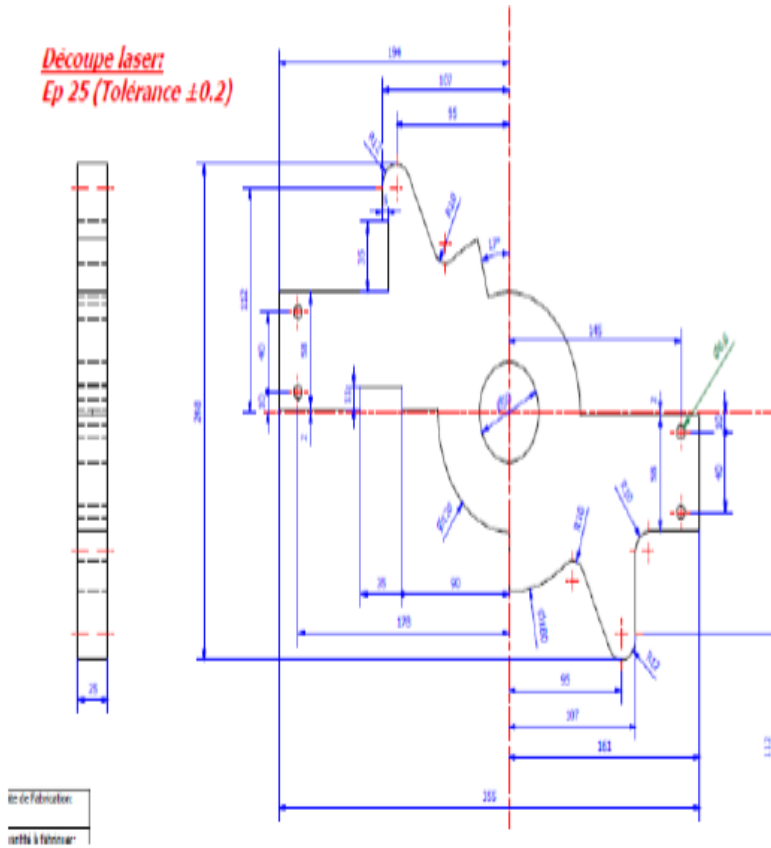

BALMER LAWRIE & CO. LTD.
IP TALOJA (NAVI MUMBAI)
SCISSOR ARM LOWER-PLAN

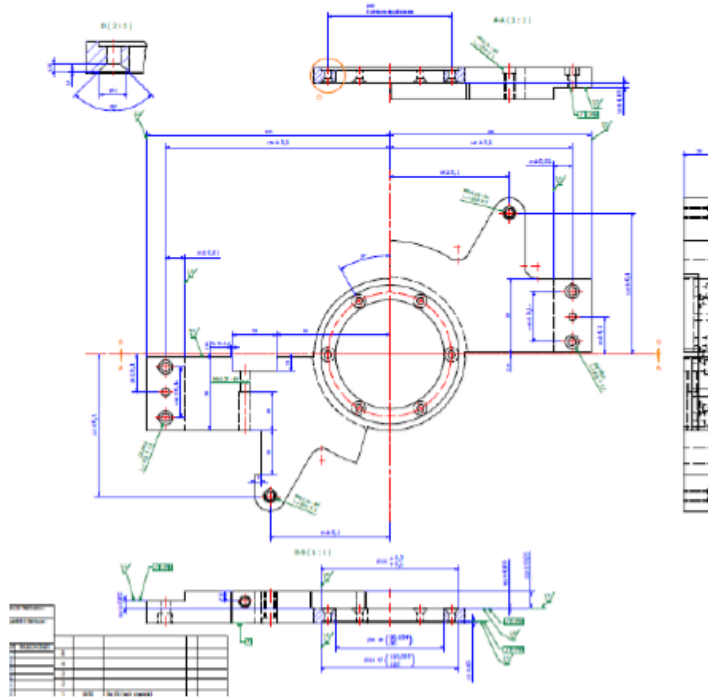

BALMER LAWRIE & CO. LTD.
IP TALOJA (NAVI MUMBAI)
SCISSOR ARM UPPER-DETAILED
VIEW

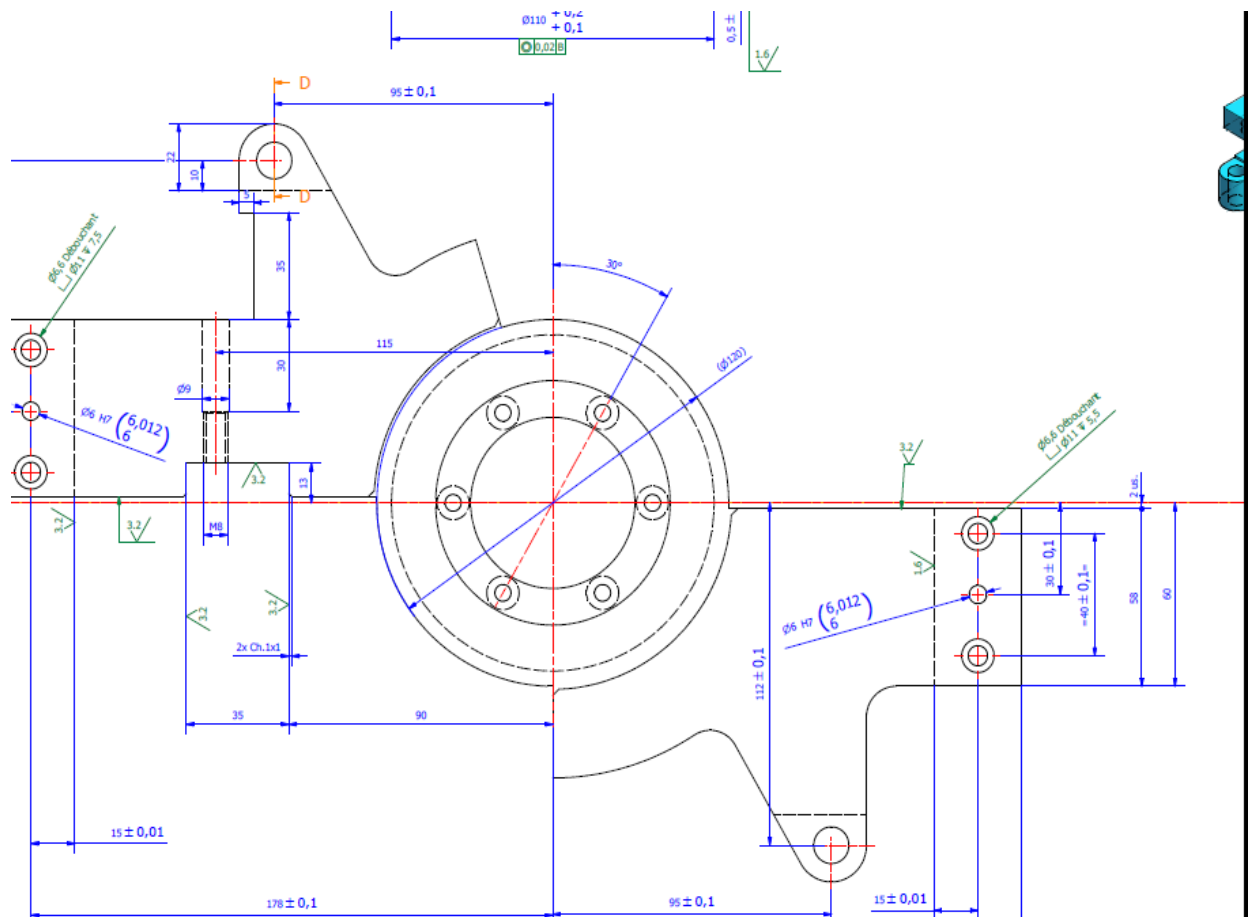

BALMER LAWRIE & CO. LTD
IP TALOJA (NAVI MUMBAI)
SCISSOR ARM LOWER-DETAILED

Découpe laser:
Ep 25 (Tolérance ±0.2)

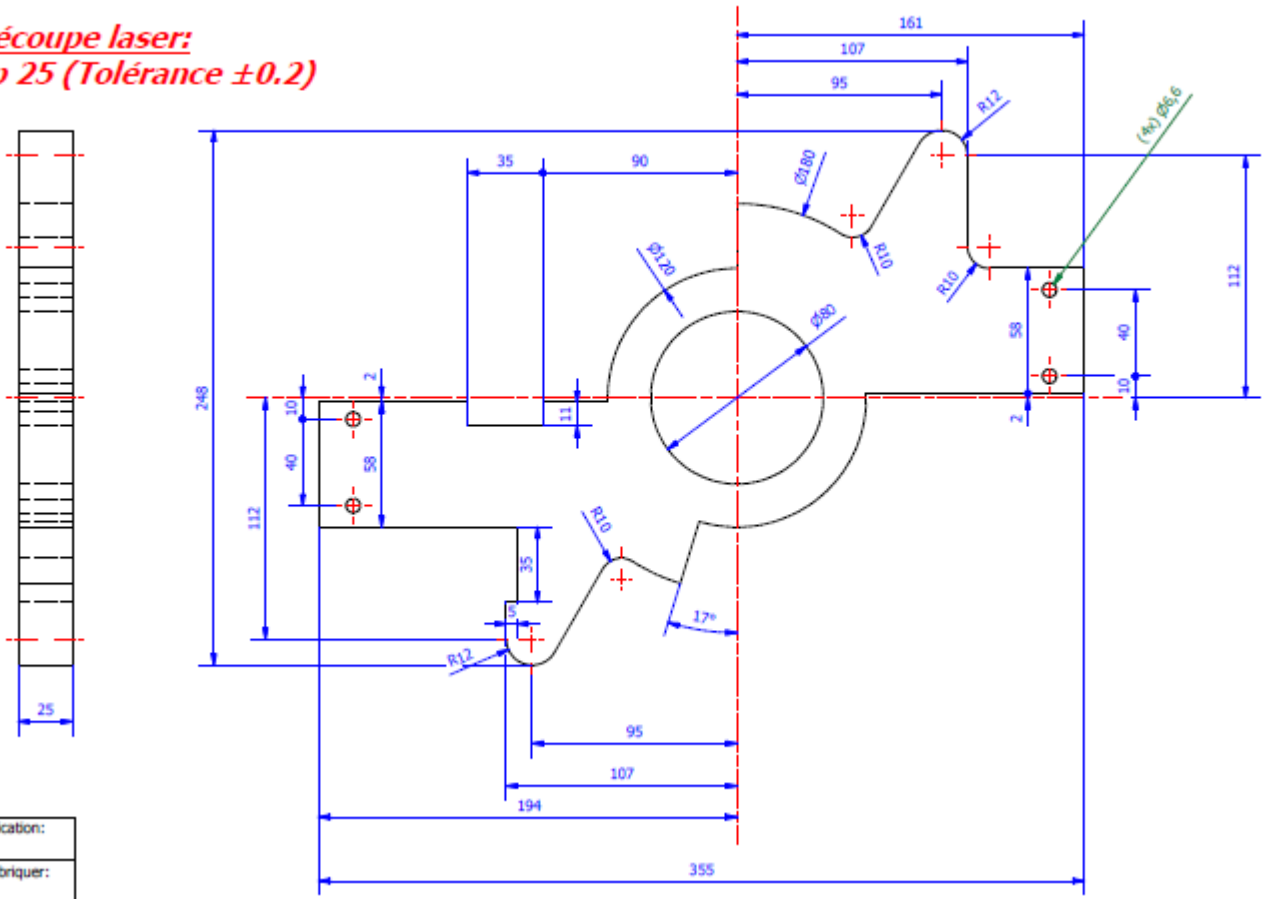

BALMER LAWRIE & CO. LTD.
IP TALOJA (NAVI MUMBAI)
SCISSOR ARM UPPER – PLAN

ANNEXURE IV

G. PRICE BID – to be filled by BIDDER

S.No.	Description	Quantity	UOM	Rate
				Rs./each
A	Set of Bushes of Scissors Arm Assembly	3	set	
B	Scissors Arm Upper	3	Nos	
C	Scissors Arm Lower	3	Nos	
D	Total Value [A+B]			
E	Freight			
F	CGST			
G	SGST			
H	IGST			
I	LESS :[CGST+SGST]/IGST			
J	Net Delivered Price			

I / We have studied the Tender Documents carefully and have quoted our lowest rates, in accordance with the **Special Terms and Conditions and General Terms & Conditions** as laid down in the Tender Documents.

Company Seal	Signature	
	Name	
	Designation	
	Company	
	Date	

ANNEXURE - V

H. ADDRESS OF BALMER LAWRIE PLANT

Balmer Lawrie & Co Ltd, Industrial Packaging
G 15,16,17, MIDC, Taloja,
District – Raigad (Maharashtra) – 410208

I. BANK DETAILS FOR SWIFT/RTGS TRANSFERS

1	Name	BALMER LAWRIE & CO. LTD.,
2	Supplier Code	
3	Permanent Account Number (PAN)	AABCB0984E
4	Particulars of the Bank Account	
	A. Name of the Bank	Standard Chartered Bank
	B. Name of the Branch	M.G. Road
	C. Branch Code	29
	D. Address	90, M.G. Road, Mumbai-400001, India
	E. City Name	Mumbai
	F. Telephone No.	+9122 22683300
	G. NEFT/RTGS IFSC Code	SCBL0036046
	H. 9 digit MICR code appearing on the cheque book	400036002
	I. SWIFT CODE	SCBLINBBXXX
	J. Type of Account	Current
	K. Account No. appearing on the cheque	222-0-526803-6
5	Vendor's e mail id	

ANNEXURE-VII**J. CODE OF CONDUCT FOR BALMER LAWRIE & CO. SUPPLIERS.**

This Code of Conduct defines the basic requirements placed on Balmer Lawrie & Co.'s suppliers of goods and services concerning their responsibilities towards their stakeholders and the environment. Balmer Lawrie & Co. reserves the right to reasonably change the requirements of this Code of Conduct due to changes of the Balmer Lawrie & Co. Compliance Program. In such event Balmer Lawrie & Co. expects the supplier to accept such reasonable changes.

The supplier declares herewith:

f Legal compliance

- o to comply with the laws of the applicable legal system(s).

f Prohibition of corruption and bribery

- o to tolerate no form of and not to engage in any form of corruption or bribery, including any payment or other form of benefit conferred on any government official for the purpose of influencing decision making in violation of law.

f Respect for the basic human rights of employees

- o to promote equal opportunities for and treatment of its employees irrespective of skin color, race, nationality, social background, disabilities, sexual orientation, political or religious conviction, sex or age;
- o to respect the personal dignity, privacy and rights of each individual; o to refuse to employ or make anyone work against his will;
- o to refuse to tolerate any unacceptable treatment of employees, such as mental cruelty, sexual harassment or discrimination;
- o to prohibit behavior including gestures, language and physical contact, that is sexual, coercive, threatening, abusive or exploitative;
- o to provide fair remuneration and to guarantee the applicable national statutory minimum wage;
- o to comply with the maximum number of working hours laid down in the applicable laws;
- o to recognize, as far as legally possible, the right of free association of employees and to neither favor nor discriminate against members of employee organizations or trade unions.

f Prohibition of child labor

- o to employ no workers under the age of 18;

f Health and safety of employees

- o to take responsibility for the health and safety of its employees;
- o to control hazards and take the best reasonably possible precautionary measures against accidents and occupational diseases;
- o to provide training and ensure that employees are educated in health and safety issues;
- o to set up or use a reasonable occupational health & safety management system;

f Environmental protection

- o to act in accordance with the applicable statutory and international standards regarding environmental protection;
- o to minimize environmental pollution and make continuous improvements in environmental protection;
- o to set up or use a reasonable environmental management system;

f Supply chain

- o to use reasonable efforts to promote among its suppliers compliance with this Code of Conduct;
- o to comply with the principles of non-discrimination with regard to supplier selection and treatment.

Annexure – VIII

**K. BIDDER TO SUBMIT ON THEIR LETTER PAD
(APPLICABLE TO ONLY MSE VENDORS FOR
AVAILING BENEFITS
AS PER PUBLIC PROCUREMENT POLICY FOR MSE'S
ORDER 2012.)**

Dated

I/We, M/s,
address.....,
hereby declare that I/We are registered as MSE supplier and have
registered our Udyog Aadhar Memorandum (UAM)
Number.....on Central Public Procurement Portal
(CPPP).

Balmer Lawrie & Co. Ltd reserves the right to verify the authenticity
of the above claim through CPPP.

Company Authorized Signatory
(Seal & Stamp)

Annexure –IX**LIST OF DESIGNATED OFFICERS RESPONSIBLE FOR RELEASING PAYMENT**

Following are the details of designated officers responsible for processing of invoices/payment :-

Sr.No.	Industrial Packaging -Location	Contact Person	Contact No.	email ID
1	Silvassa	Mr. Prasoon Aggarwal	9555587372	aggarwal.p@balmerlawrie.com
2	Kolkata	Mr. Shuvam Banerjee	9831737098	banerjee.shuvam@balmerlawrie.com
3	Chennai	Mr. Manoj Karmakar	8124056521	karmakar.mk@balmerlawrie.com
4	Chittoor	Mr. Pravin K Singh	9883325136	singh.pk@balmerlawrie.com
5	Asaoti	Mr. D P Sharma	9717695849	sharma.dp@balmerlawrie.com
6	Taloja	Ms. Rekha	9867420162	rekha.rr@balmerlawrie.com
7	Vadodara	Mr. Vishal Gokharan	9819520229	vishal.g@balmerlawrie.com

You are requested to contact the above officers for any queries pertaining to Invoices/payment.