



बामर लॉरी एण्ड कं. लिमिटेड
Balmer Lawrie & Co. Ltd.

REFINERY & OILFIELD SERVICES
21, Netaji Subhas Road
Kolkata 700 001

TENDER DOCUMENT

FOR

FABRICATION, TESTING & SUPPLY OF
DECANTER MODULE WITH
MECHANICAL & ELECTRICAL WORKS
AND
DECANTED OIL TANK

Tender No.: ROFS/CAPEX/19-20/ENQ/15

Dated: 14.01.2020

Tender Due date & Time : 03.02.2020, 16:00 Hrs

PART-I (Un-Priced)

INDEX

SL. NO.	SUBJECTS
1.0	Check-List
2.0	Notice Inviting Tender
3.0	Instructions to Bidders regarding Bid Submission
4.0	Detailed Scope of Work and Technical Specifications
5.0	Proforma Bank Guarantee for Performance –Attachment - I
6.0	Details of Experience – Attachment - II
7.0	Deviation Statement – Attachment - III
8.0	Vendor’s Information – Attachment –IV

**CHECK LIST FOR SUBMISSION OF TENDER
(TO BE SUBMITTED WITH UN-PRICED PART)**

Tenderers are requested to fill up this Check List and attach supporting documentary evidence.

Sl No.	Submission of Document	Bidder's Confirmation/Submission (Yes / No)
1	Earnest Money Deposit	
2	90 days validity of the offer confirmation	
3	Audited Annual Reports (for past three years)	
4	Copy of Work Order and Completion Certificates for similar executed works as per Pre-qualification Criteria	
5	Power of Attorney of the Signatory	
6	PAN	
7	GSTIN Registration	
8	Valid MSE Registration certificate as per NIT	
9	In case of SC/ST or woman entrepreneur, please provide details as per tender	
10	Price Schedule in Un-priced Bid duly blanked out and signed	
11	Tender Document (along with addendum if any) duly signed and stamped on all pages	
12	Price quoted strictly as per Tender price schedule	
13	Payment Terms in compliance to tender requirement	
14	Completion/Delivery Period in compliance to tender requirement	
15	LD clause in compliance to tender requirement	
16	Warranties and Guarantee in compliance to tender requirement	
17	All others Technical & Commercial Terms & Conditions shall remain unaltered as per Tender document	



Balmer Lawrie & Co. Ltd.
Refinery & Oilfield Services
NOTICE INVITING TENDER

Tender No. : ROFS/CAPEX/19-20/ENQ/15
Date : 14/01/2020
Due Date & Time : 03/02/2020, 16:00 Hrs
Date & Time of Opening : 03/02/2020, 16:30 Hrs

BALMER LAWRIE & CO. LTD. (BL) invites ONLINE bids in 2 bid system from experienced & resourceful fabricators/vendors for fabrication, testing & supply of decanter module with Mechanical & electrical works and decanted oil tank as mentioned below.

1.0 SCOPE OF WORK

The scope of work covers generally but not limited to the followings:

- A. Fabrication, assembly of 1 no Container Module of Size 20 ft (L) X 8 ft (W) X 9 ft (H) as per the detailed Scope of Work
- B. Assembly and installation of 1 no Decanter Centrifuge (Free issue by BL) inside the container module.
- C. Fabrication & Installation of 1 no Mild Steel Recovered Oil tank-5 KL capacity
- D. Mechanical & Piping Work within the Container Module as per detailed Scope of Work & Price Schedule
- E. Electrical Work within the Container Module as per as per detailed Scope of Work & Price Schedule.

2.0 PRE-QUALIFICATION (PQ) CRITERIA

- i) Average annual turnover of the tenderer shall be minimum of **Rs 18 Lakh** during last three financial years ending 31st March, 2019 preferably in related business. The tenderer/bidder shall submit Balance Sheet/Profit & Loss Account for last 3 years.
- ii) The tenderer/bidder should have successfully executed work of similar nature of the following minimum values during past seven (7) years ending last day of month previous to the one in which tenders are invited:-
 - a) **3 jobs** each of value not less than **Rs 3.6 Lakh** or
 - b) **2 jobs** each of value not less than **Rs 4.5 Lakh** or
 - c) **1 job** of value not less than **Rs 7.2 Lakh**

Copy of work order(s) and/or completion certificate(s) should be enclosed as supportive documents. In the event of work orders from Balmer Lawrie, copy of work order may also be considered.

Similar Nature of Work shall be defined as Manufacturing or Repairing of Containers..

OTHER REQUIREMENTS

- iii) Copy of PAN Card, GST Registration Certificate and shall be submitted.
- iv) Tender document duly signed and company seal (as an acceptance of all our terms and conditions) shall also be submitted
- v) `Affidavit' in non-judicial stamp paper in case of proprietorship firm, "Partnership Deed" in case of Partnership Firm, "Memorandum & Article of Association" in case of Limited Company.

3.0 DELIVERY/COMPLETION PERIOD-EX WORKS

Time is the essence of the contract. The supply of the container along with all mechanical and electrical work must be completed must be completed within **8 (Eight) weeks** from the date of handing over of free issue item by BL at vendor's works.

However, the contract/order shall remain valid for **4 (Four) months** from the date of order.

4.0 TENDER DOCUMENTS

Tender Documents comprise two parts viz. Part-I (Un-priced) and Part-II (Priced). The Un-priced Part consists of Notice Inviting Tender, Instruction to Bidders, Detailed scope of Work and Technical Specifications. The Priced Part consists of Price Schedule.

5.0 VALIDITY OF OFFER

Tenderers shall keep their offer valid for a period of **90 (ninety) days** from the due date of this tender. Validity may be extended, if so advised by BL.

6.0 EARNEST MONEY DEPOSIT

Unpriced Bid should be accompanied by a Bank Draft of **Rs 5,000/- (Rupees Five Thousand only)** favouring `Balmer Lawrie & Co. Ltd.' payable at Kolkata towards Earnest Money Deposit (EMD).

Bidders registered as Micro & Small Enterprises (MSEs) shall be exempted from submission of EMD (as per clause 15). Declaration of Udyog Aadhar Memorandum [UAM] number by the MSE vendors on Central Public Procurement Portal [CPPP] is mandatory to qualify for availing the benefits as per Public Procurement Policy for MSEs.

- 6.1 EMD of successful bidders will be retained with us till submission of Security Deposit. No interest shall be payable towards EMD amount.

- 6.2 For the unsuccessful bidders, the EMD will be refunded only after the successful bidder has accepted the work/purchase order and the acknowledgment of the same has been received by BL/the owner.
- 6.3 EMD is liable to forfeiture in the event of:
- a) Withdrawal of offers during validity period of the offer
 - b) Non acceptance of orders by the bidder within the stipulated time after placement of order.
 - c) Any unilateral revision made by the bidder during the validity period of the offer.
 - d) Non-performance of the bidder during the tenure of work.
 - e) Bidders submitting false/fabricated/bogus documents in support of their credentials

7.0 SECURITY DEPOSIT

The bidder, with whom the contract is decided to be entered into and intimation is so given will have to make a Security Deposit @ 2.5% of the basic Order value in the form of Demand Draft drawn in favour of Balmer Lawrie & Co. Ltd. payable at Kolkata within 15 days from the date of intimation of acceptance of their tender, failing which Balmer Lawrie & Co. Ltd. reserves the right to cancel the Order. Security Deposit shall be released after completion of work.

8.0 BASIS OF EVALAUTION

Bidders shall have to quote for all the items of work delineated in the Priced Schedule. In case of any unquoted item in Price Schedule, bid is liable to be cancelled. Bidders will be shortlisted through evaluation of their Unpriced Bids based on fulfilment of pre-qualification criteria i.e. submission of all required PQ documents and other required documents, EMD/MSE Certificate as per the instructions contained in the tender document. Price Bids will be opened only for the bidders whose Unpriced Bids (Part-I) are found to be acceptable.

L1 Bidder(s) will be determined based on basic amount (excluding GST). In case of any discrepancy between quoted rates and amounts. Quoted rate will prevail.

9.0 FORCE MAJEURE

Any delay in or failure of the performance of either part hereto shall not constitute default hereunder or give rise to any claims for damage, if any, to the extent such delays failure of performance is caused by occurrences such as Acts of God or an enemy, expropriation or confiscation of facilities by Government authorities, acts of war, rebellion, sabotage or fires, floods, explosions, riots, or strikes. The Vendor shall keep records of the circumstances referred to above and bring these to the notice of the Engineer-In-Charge in writing immediately on such occurrences. The amount of time, if any, lost on any of these counts shall not be counted for the delivery period. On decision of BL/Owner arrived at after consultation with the Vendor, shall be final

and binding. Such a determined period of time be extended by the Owner to enable the Vendor to deliver the items within such extended period of time.

If Vendor is prevented or delayed from the performing any of its obligations under this agreement by Force Majeure, then Vendor shall notify Owner the circumstances constituting the Force Majeure and the obligations performance of which is thereby delayed or prevented, within seven days of the occurrence of the event.

10.0 ARBITRATION

Any dispute or difference arising under this Contract shall be referred under jurisdiction of Kolkata to a sole arbitrator to be appointed by the Chairman & Managing Director, Balmer Lawrie & Co. Ltd. and the provisions of Arbitration Act, 1996 including any statutory modifications or enactment thereof shall apply to the Arbitration proceedings. The fees of the arbitrator, if any, shall be shared equally by both the parties. The award shall be a speaking award stating reason therefor and is final & binding on the parties. The proceeding shall be conducted in English language and courts at Kolkata will have exclusive jurisdiction to settle any dispute arising out of this contract.

11.0 JURISDICTION

Notwithstanding anything contained in any other law, the courts in the city of Kolkata along shall have jurisdiction in respect of all or anything arising under this agreement and any award or awards made by the sole arbitrator

12.0 TERMINATION OF CONTRACT

In case of violation/breach of any agreed terms and conditions of contract and persistently failure/negligence to observe and perform all or any of the acts, deeds, matters or things to be observed and performed by the Supplier requiring the Owner to observe or perform the same, BL may cancel/terminate this contract . In such case, the EMD and/or Security Deposit of the Supplier will be forfeited.

13.0 RIGHT OF ACCEPTANCE/REJECTION

Mere issue of tender document, participation in e-procurement portal and submission of bids does not necessarily qualify for consideration of bids. Conditional offer or offer with deviations will not be accepted. M/s Balmer Lawrie & Co. Ltd. reserve the right to accept or reject any tender either in part or in full without assigning any reason whatsoever.

14.0 NON-CONFORMANCE

Tenders not conforming to the above mentioned requirements are liable to be rejected.

15.0 TENDER CONDITIONS FOR BENEFITS / PREFERENCE FOR MICRO & SMALL ENTERPRISES (MSES)

- 15.1 As Per Public procurement Policy for Micro & Small Enterprises (MSEs) Order, 2012 issued vide Gazette Notification dated 23.03.2012 by Ministry of Micro, Small and Medium Enterprises of Govt. of India, MSEs must be registered with any of the following in order to avail the benefits/preference available vide Public Procurement Policy MSEs Order,2012
- a. District Industries Centers (DIC)
 - b. Khadi and Village Industries Commission (KVIC)
 - c. Khadi and Village industries Board and Coir Board
 - e. National Small Industries Corporation (NSIC)
 - f. Directorate of Handicraft and Handloom
 - g. Any other body specified by Ministry of MSME
- 15.2 MSEs participating in the tender must submit the certificate of registration with any one of the above agencies.
- 15.3 The registration certificate issued from any one of the above agencies must be valid as on close date of the tender. The successful bidder should ensure that the same is valid till the end of the contract period.
- 15.4. The MSEs who have applied for registration or renewal of registration with any of the above agencies/bodies, but have not obtained the valid certificate as on close date of the tender, are not eligible for exemption/preference.
- 15.5 Registered MSME vendors shall be exempted from need to furnish EMD, subject to their submission of registration details.
- 15.4 Declaration of Udyog Aadhar Memorandum [UAM Number] number by the MSME vendors on Central Public Procurement Portal [CPPP] is mandatory to qualify for availing the benefits as per Public Procurement Policy for MSMEs
- 15.5. Price Preference - Subject to meeting terms and conditions stated in the tender document including but not limiting to prequalification criteria, 25% of the total quantity of the tender is earmarked for MSEs registered with above mentioned agencies/bodies for the tendered item. Where the tendered quantity can be split, MSEs quoting a price within a price band of L1+15% shall be allowed to supply 25% of total tendered quantity provided they match L1 price. In case the tendered quantity cannot be Split, MSE shall be allowed to supply total tendered quantity provided their quoted price is within a price band of L1+15% and they match the L1 price. In case of more than one such MSEs are in the price band of L1+15% and matches the L1 price, the supply may be shared proportionately.

For Further clarity in this regard a table is furnished below:

Type of Tender	Price Quoted by MSE	How to Finalize the Tender
Can be split	L1	Full Order on MSE
Can be split	Not L1 but within L1+15%	25% order on MSE subject to matching L1 price
Cannot be split	L1	Full Order on MSE
Cannot be split	Not L1 but within L1+15%	Full Order on MSE subject to matching

15.6 Out of the 25% target of annual procurement from micro and small enterprises, 4% has been earmarked for procurement from MSEs owned by SC or ST entrepreneurs and 3% from within 25% has been earmarked from supply from the MSEs owned by Woman entrepreneurs. Provided that, in event of failure of such MSEs to participate in tender process or meet tender requirement and L-1 price, 4%/ 3% sub-target for procurement earmarked for MSEs owned by SC or ST entrepreneurs and woman entrepreneurs respectively shall be met from other MSEs.

15.7 To qualify for entitlement as SC/ST owned MSE, the SC/ST certificate issued by District Authority must be submitted by the bidder in addition to certificate of registration with any one of the agencies mentioned in paragraph (I) above. The bidder shall be responsible to furnish necessary documentary evidence for enabling BL to ascertain that the MSE is owned by SC/ST. MSE owned by SC/ST is defined as:

- a. In case of proprietary MSE, proprietor (s) shall be SC/ST
- b. In case of partnership MSE, The SC/ST partners shall be holding at least 51% shares in the enterprise.
- c. In case of Private Limited Companies, at least 51% share shall be held by SC/ST promoters.

16.0 CONFLICT OF INTEREST

The bids of any bidder may be rejected if a conflict of interest between the bidder and the company is detected at any stage.

18.0 PAYMENT TERMS

- i) **90% of basic order value** along with full taxes and duties will be paid on completion of work after inspection and certification of work by BL.
- ii) **10% of basic order value** shall be paid against submission of PBG (Performance Bank Guarantee) of equivalent amount with validity of 12 months from the date of commissioning of the Decanter Module or eighteen (18) months from the date of supply whichever is earlier. PBG shall be submitted after completion of all work.

19.0 WARRANTIES & GUARANTEES

Vendor shall guarantee BL and their authorized representative against any and all defects in manufacturing, workmanship, materials and performance for a period of twelve (12) months from the date of commissioning or eighteen (18) months from the date of supply whichever is earlier. Should any defect develop during the guarantee period, it shall be remedied promptly free of charge by the Vendor and all expenses for transportation of goods necessitated for such repairs or replacement shall be borne by the vendor.

20.0 OTHER TERMS & CONDITIONS

- i) The free issue materials such as Decanter Centrifuge, Pump, Panels and other electrical free issue items will be delivered to the vendor's premises by Balmer Lawrie's vendor. Unloading of all these free issue materials are under the scope of the tender.
- ii) After completion of work, the container is to be loaded on to designated trucks/ trailers placed by BL at vendor's premises. Loading of material on to truck/ trailer is to be done by the vendor.
- iii) Inspection of work is to be carried out by Balmer Lawrie at vendor's premises. Vendor shall make all necessary arrangements for inspection of work as per BL's instructions, without any additional charge.

21.0 LIQUIDATED DAMAGES

A reduction @0.5% of the basic order value per week or part thereof subject to a maximum of 5% of the basic order value will be applicable for delay in completion of work.

22.0 TAXES & DUTIES

GST shall be mentioned separately as per price schedule. Any taxes and duties other than GST shall be included in the basic rate. Prices should be firm till completion of the job and no escalation for whatsoever reason shall be granted. Our GST Registration No. 19AABCB0984E1ZS for the state of West Bengal.

For further clarification on tender document, please contact Sk Abu Jafor, Manager (Business Development), Phone no +9133 2222 5283 Fax no. : + 91-33 2222 5333, E-Mail : jafor.a@balmerlawrie.com.

Yours faithfully,
for, **BALMER LAWRIE & CO. LTD.**

(A Bandyopadhyay)
Head (ROFS)



Balmer Lawrie & Co. Ltd.
Refinery & Oilfield Services

INSTRUCTIONS TO BIDDER REGARDING BID SUBMISSION

1.0 PROCEDURE FOR BID SUBMISSION

The Tender Document comprises of two Bids viz Unpriced Part – I and Priced Part – II. The submission of offer can only be made through e-bidding as per following guidelines: :

1.1 BID SUBMISSION

The bidders shall submit their response through bid submission to the tender on e-Procurement platform at <https://balmerlawrie.eproc.in> by following the procedures given below. The bidder would be required to register on the e-procurement market place <https://balmerlawrie.eproc.in> and submit their bids on line. The bidders shall submit their offers comprising the Tender Document (Part-I), duly filled up (wherever required), stamped and signed along with all pre-qualification documents, EMD. The bidders shall download the tender document, upload the same along with scanned copies of all the relevant certificates, documents etc., duly filled in, stamped and signed, in support of their eligibility criteria/NIT in the e-Procurement web site. However, bulky documents which could not be uploaded may be sent along with Unpriced Bid (Part-I) of the Tender Document, duly stamped and signed to the Tender Inviting Authority before date of tender opening along with the bank draft towards EMD amount (unless otherwise MSME). A copy of Priced Bid **without rate and amount** but with percentage of taxes and duties should be submitted along with Unpriced Bid. **The price bid file in xls format shall be downloaded from the website, bidder to fill in their item-wise rates on soft copy, print, stamp, sign, scan and upload the same. Total Contract Price with GST shall be entered as 'Project Contract Total' while uploading price bid.**

1.1.1 Registration with e Procurement platform

For registration and online bid submission tenderer may contact the following officials at the HELP DESK of M/s C1 India on browsing to the website <https://balmerlawrie.eproc.in> as mentioned below: during business hours (10:00 a.m. to 06:30 p.m.) from Monday to Friday (Excluding holidays of the Company):

Dedicated email : blsupport[at]c1india[dot]com			
Dedicated Helpdesk for Balmer Lawrie			
<u>Contact Person</u>	<u>E-Mail ID</u>	<u>Tel. No.</u>	<u>Helpdesk Nos are open from</u>
1. Mr.Tirtha Das (Kolkata)	tirtha.das@c1india.com	+91-9163254290	MON - FRI
2. Mr. CH. Mani Sankar (Chennai)	chikkavarapu.manisankar@c1india.com	+91-6374241783	MON - SAT
3. Ms. Ujwala Shimpi (Mumbai)	ujwala.shimpi@c1india.com	+91-22-66865608	MON - FRI
4. Helpdesk Support (Kolkata)	blsupport@c1india.com	+91-8017272644	MON - SAT

Escalation Level 1		
Mr. Tuhin Ghosh	tuhin.ghosh@c1india.com	+91-8981165071
Escalation Level 2		
Mr. Sandeep Bhandari	sandeep.bhandari@c1india.com	+91-8826814007
Escalation Level 3		
Mr. Achal Garg	achal.garg@c1india.com	
In case, you are unable to get in touch with any of the Technical Support Associates, kindly drop a mail at blsupport@c1india.com mentioning your Name and Mobile No. One of our associates will get back shortly.		

1.1.2 Digital Certificate authentication

The bidder shall authenticate the bid with his Digital Certificate for submitting the bid electronically on e-Procurement platform and the bids not authenticated by digital certificate of the bidder will not be accepted on the e-Procurement platform.

All the bidders who do not have Digital Certificates need to obtain Digital Certificate. They may contact Help Desk of C1 India Pvt. Ltd.

1.1.3 Submission of Hard copies

After submission on-line bid, bidders are requested to submit the demand draft towards EMD along with original Affidavit and pre-qualification & documents (i.e. Unpriced Bid) which could not be uploaded due to its bulkiness to the following Tender Inviting Authority on/before the due date of opening date under cover of Unpriced Bid, Part - I.

Head (ROFS)
Balmer Lawrie & Co. Ltd.
Refinery & Oil Field Services
21, Netaji Subhas Road
Kolkata – 700 001

The above documents & EMD (unless bidder is a registered MSME under specific category) can be submitted either in person or through courier or by post. **Under no circumstances, physical copy of Price Bid should accompany with these documents. If price bid is submitted in hardcopy, the bid will summarily be rejected.**

Balmer Lawrie shall not take any responsibility for any delay or non-receipt of said documents. If any of the documents furnished by the bidder is found to be false / fabricated, the bidder is liable for black listing, forfeiture of the EMD, cancellation of work and criminal prosecution.

The bidder is requested to get a confirmed acknowledgment from the Tender Inviting Authority as proof of submission of hard copies.

1.1.4 Corrigendum to tender

The bidder has to keep track of any changes by viewing the addendum/ Corrigendum's issued by the Tender Inviting Authority on time-to- time basis in the e-Procurement platform. The Company calling for tenders shall not be responsible for any claims/problems arising out of this.

1.1.5 Bid Submission Acknowledgment

The user should complete all the processes and steps required for bid submission. The successful bid submission can be ascertained once acknowledgment is given by the system through bid submission number after completing all the processes and steps. Tender Inviting Authority and C1 India Pvt. Ltd. will not be responsible for incomplete bid submission by users. Users may also note that the incomplete bids will not be saved by the system and are not available for the Tender Inviting Authority for processing.

Before uploading scanned documents, the bidders shall sign on all the statements, documents, certificates uploaded by him, owning responsibility for their correctness/authenticity.

1.1.6 Disclaimer Clause

The Company (Balmer Lawrie & Co. Ltd.) nor the service provider (C1 India Pvt. Ltd.) is responsible for any failure of submission of bids due to failure of Internet or other connectivity problems or reasons thereof.

Fax/e-mail offers shall not be accepted. The company will not accept any responsibility for any delay in receipt or non-receipt of bidding document sent by post. Offers not conforming to the above mentioned requirements are liable to be rejected.

DETAILED SCOPE OF WORK & TECHNICAL SPECIFICATION

A. Fabrication, Assembly of Container Module

Size	20 ft X 8ft X 9 ft (L X B X H)
Shell	<p>The outer shell shall be manufactured from HR Sheet of IS 1079 or IS 513 or equivalent and of welded construction. The components of various profiles shall be made out from 3.2 / 4.0 / 5.0 mm thickness.</p> <p>The shell shall have Corner Casting at all corners to facilitate for easy handling. The container shall have closed structure made out of hollow sections positioned vertically at corners and intermediate positions along the periphery. Horizontal tie members with hollow section shall be provided at bottom, middle and top levels i.e. at 3 layers. Cross beams made of rectangular hollow sections shall be provided at bottom level to erect the recovered oil tank on it. Cross beams shall also be provided at about +1400 mm height (Top of Steel) from container bottom to erect the decanter centrifuge on it.</p>
Walls	<p>The side and end wall panel shall be vertically corrugated steel sheet of 1.6 / 2.0 mm thickness. The corrugated panels are continuously butt welded to form part of Side/end walls.</p> <p>However, part of Side walls & end wall shall be made out of segregated reinforced framed MS panels which can be opened during operation of the decanter. All the cut out after fixing the container module shall be weather tight. One end wall shall be provided with full height two leaf main door with locks. The door shall be effectively sealed against water ingress in closed condition by using rubber gasket profiles.</p>
Roof	<p>The roof shall be self-draining type. The roof of the shell shall be manufactured from minimum 2.0mm thick plain MS sheet conforming to IS 1079 or IS 513 or equivalent. External roof Panels shall be FRP coated. The roof shall made in separated framed panels and openable type for de-erection/removal of the decanter centrifuge.</p>
Welding	<p>The Shell of the structural cabin shall be of all weld construction. The welding is to be carried out by MIG process using CO2 as shielding gas. All the external welding shall be continuous, uniform and of full penetration.</p>
Floor	<p>This Container's floor shall have 3 mm MS sheet on structural cross members.</p>
Surface Prep.	<p>The shell shall be undergone for surface preparation through sand blasting. The dust and dirt's are to be removed by blowing dry and clean oil free compressed air before application of spray painting.</p>
Painting	<p>Painting of container as per Specification for painting mentioned below.</p>

Dispatch of Container	Transportation of the container will be carried out by BL. Loading of the container onto BL's designated truck trailer after completion of work
-----------------------	---

Specifications for Painting for the Container

The specifications for painting of containers shall be as follows:

- i) **Surface Preparation** : Entire surface of all structural members shall be properly cleaned through scrapping and power brushing as required to expose the bare metal surface.
- ii) **Painting:** : The cleaned steel surface shall be painted by spray painting process.
- iii) **Inner & Outer surface:** : Two coats of Polyurethane based paint over one coat of zinc rich primer.
- iv) **Under frame and surface:** : Bituminous paint over one coat of zinc rich primer.
- v) **Thickness of Painting** : The aggregate painting thickness shall not be less than 110 micron DFT for all the above categories.
- v) **Shade & Logo** : Shade of paint will be confirmed by BL later. After painting, Logo of Balmer Lawrie/ Oreco, 4 Nos. to be painted on the container.

B. Assembly and Installation of 1 No Decanter Centrifuge (Free issue by BL)

- 1) Unloading of the consignment related to the Decanter Centrifuge and storing of the same at safe place at vendor's works.
- 2) Assembly of the decanter centrifuge as per the technical supervision of Original Equipment Manufacturer's engineer with supply of necessary tools, tackles and manpower as required.
- 3) Erection of the decanter centrifuge within the container module.
- 4) Chain pulley, hoists as required for assembly, erection shall be arranged by the vendor.
- 5) Foundation Bolts as required for mounting of the decanter shall be supplied by the vendor.
- 6) Welding works as required for erection shall be under the scope of vendor.
- 7) Total Weight of the assembled decanter is about 3500 Kg (aprox). Weight of single heaviest component 1550 Kg.

C. Fabrication & Installation of Recovered Oil tank-5 KL capacity

- 1) Residual engineering, material procurement, fabrication, testing, surface preparation, application of 2 coats of primers and 2 coats finish paints etc. for Rectangular Crude Oil Storage Tank fabricated from Mild Steel Plates
- 2) Plate thickness shall be **5 mm**.
- 3) The tank bottom shall be supported on ISMC 100 or suitable structural section
- 4) Net capacity of the tank shall be minimum 5 KL
- 5) The tank shall be completed with all required nozzles for Oil inlet, oil outlet, vent, drain, and manholes. Blind flanges, gasket, nut bolts as required
- 6) Water for Hydro testing shall be arranged by vendor.
- 7) The tank shall be erected at the bottom of the container module duly welded with the bottom beams.

D. Mechanical & Piping Work [Supply (except Free issue items) & Installation]

- 1) 1 no new Screw Pump (Capacity 20 Cum/ Hr , FLP Motor of 11.5 KW) shall be as free issue item by BL.
- 2) The pump shall be unloaded by the vendor and erected making a structural frame at the bottom of the container beside the recovered oil tank.
- 3) The pump suction shall be connected with recovered oil tank including as per piping drawing.
- 4) Fabrication, erection of structural steel work for making platforms at 2 tiers with galvanised steel gratings which will act as working platform at bottom level around tank and pump and also around the centrifuge decanter at suitable level from bottom of container. This will be paid under separate item as per price schedule.

- 5) Supply & application of Paint (Two coats of Polyurethane based paint over two coat of zinc rich primer) on steel work.

Piping Work

Scope of this work covers Supplying, laying, testing and commissioning of above-ground piping including cutting, edge preparation, fit up, bending, pre-heating wherever required, welding etc.; hook-up with equipment flanges ; installation of all type of valves, fittings (made from seamless pipe only) of all sizes flanges (SORF ASA 150# , ASME B 16.5), blind flanges, hoses including fixing of all types of Spiral wound gaskets of SS316, bolts, studs and nuts washers, 'U' clamps etc. as detailed below:

- 1) Piping with Carbon Steel Seamless Pipe of mainly 4 Inch diameter or any other sizes, Schedule - 40, Material - ASTM A 106, Gr - B, Ends - BE, Dmn. Std. - ASME B36.10 shall be used for suction and discharge connection of centrifuge decanter and pump
- 2) 6 inch mating flange, reducer shall be provided for pipe connection of liquid outlet chute of decanter with top nozzle of recovered oil tank. Forged SORF Flanges & Blind flanges of ASA 150#, ASME B 16.5 shall be used.
- 3) Cast Steel Ball Valves (3 inch/4 inch size) of 80 Deg C temperature rating shall be supplied and erected in the suction and discharge side of screw pump. Valve of 2 inch size shall be provided for sample collection.
- 4) Spiral Wound Gaskets as per Std. B 16.20 - ASME B16.5, Material - SP.WND SS316+CAF shall be supplied and installed in flanged connections.
- 5) During the erection of the piping the Contractor shall provide proper number and size of bolts and nuts as per requirement.
- 6) Joining of pipes shall be accomplished by butt welding connections.
- 7) Necessary spool piece with reducers and or elbow with both side flanges for connection of pump, decanter with hoses shall be fabricated.

E. Electrical Work [Supply (except Free issue items) & Installation]

The scope of work shall include but will not be limited to taking receipt of free issue materials (to be issued by BL), cables, termination kits, earthing materials including other necessary erection materials, consumables, tools and tackles, testing equipment and sundry items to complete the installation for satisfactory and trouble free operation.

- 1) Following are the list of Free Issue FLP items/materials which shall be installed tested and commissioned within the container modules as instructed by BL.
 - a) 30 KW VFD Drive Panel for Decanter Centrifuge [Size H-1200 X W-600 X D-450 (in mm)]
 - b) Local Control Station
 - c) 40W Tube Light/36 Watt LED Well Glass Fixtures
 - d) 16 amp Isolator switches
 - e) 4 way Lighting Junction Box
- 2) Necessary mounting structure shall be fabricated for erection of the Panels on the container wall for installation of Decanter drive panel, Pump Local control station. No extra payment will be made regarding that. Power cable, earthing cable shall be dressed and saddled neatly on the floor/wall of the
- 3) Necessary interconnection between the drive panels and motors shall be done with Supply & laying of power cable along with termination kits as per price schedule.
- 4) Supply & Laying of Control cables along with termination kits for installation of LCS.
- 5) Supply & Laying of Lighting Cables along with termination kits for Light Fittings, sockets etc.
- 6) Necessary earthing system shall be installed with supply and installation materials for double earthing of Starter Panels, Motors etc.
- 7) After completion work, necessary checking, testing and commissioning of completed work shall be done.

LIST OF APPROVED MAKE

Sl. No.	Item Description	Preferred Make
1	Cable & Wires	: CCI/ RPG Asian/ / Polycab/ Havells/RR
2	Valves	: KBL/H sarkar / Hawa Engineers /Upadhya/ Audco/ BDK Engg/ Aira Auro
3	Pipes	: Tata / Jindal /SAIL / (E.A.M)
4	Steel	: SAIL/RINL/TATA/JINDAL/ESSAR/BHUSAN
5.	Paint	:Berger/Asian Paints/Nerolac/ CDC Carboline/ Nicholson/ Shalimar Paints/

LIST OF DRAWINGS

Sl. No.	Title	Drawing No.	Rev	Date	Sheet No
1	GA drawing of Decanter Centrifuge	ROFS/BLABO-01/DCNTER/01	0	09-01-2020	Sheet 1 of 1
2	Arrangement for Mounting Decanter Centrifuge	ROFS/BLABO-01/DCNTER/02	0	03-01-2020	Sheet 1 of 1
3	GA Drawing of Recovered Oil Tank, Cap: 5KL	ROFS/BLABO-01/ROT/03	0	03-01-2020	Sheet 1 of 1

Note: Above mentioned drawings are for indication/guidance only. The vendor shall prepare fabrication drawings of module structure & tank and submit to owner for approval before fabrication.

ATTACHMENT-I**To**

Balmer Lawrie & Co. Ltd.
 Refinery & Oilfield Services
 21, Netaji Subhas Road
Kolkata – 700 001

BG No. : _____
 DATED : _____
 VALID UPTO : _____

This deed of Guarantee made this ____ day of ____ 20__ by the _____ a Bank registered under the _____ and having its registered office at _____ and wherever the context so requires includes its successors and assigns (hereinafter called 'The Surety') in favour of Balmer Lawrie & Co. Ltd. a Company registered under Indian Companies Act and having its registered office at 21, Netaji Subhas Road, Kolkata 700001 and wherever the context so requires include its successors and assign (hereinafter called the Company).

Whereas

1. The Company has placed a Purchase Order No. _____ dated _____ (hereinafter referred to as the Order) on M/s. _____ a Company registered under Indian Companies Act 1956 having its registered office at _____ and whereas the context so require includes its successors and assigns (hereinafter called or referred to as the Supplier).
2. Under the terms of the order, the supplier is required to furnish the Company at his own cost a Bank Guarantee for an amount of Rs. _____ (Rupees _____ only) being the amount equivalent to ____% of the total value of the order for fulfilling the contract.
3. The Surety at the request of the Supplier, agreed to issue Bank Guarantee in terms of the said order on behalf of the Supplier and the Company has agreed to accept the same. It is hereby stipulated and agreed that the Supplier shall repair or replace free of cost equipment, machinery, its parts and components found defective on account of Workmanship or defective material or inferior manufacturer, as mentioned in Warranty & Guarantee clause of the order for a period of 12 months from the date of last delivery or 18 months from the date of commissioning.
4. The Surety binds himself to pay to the extent of Rs. _____ in case of failure on the part of the Supplier to perform this guarantee provided the Company inform the Surety in writing to this effect.
5. Notwithstanding anything contained hereinafter the liability of the Surety in respect of this guarantee is restricted to Rs. _____ being ____ % value of the order.
6. The Surety shall not be discharged or released from this guarantee by any arrangement between the Company and the Supplier with or without consent of the Surety or by any alteration in the obligation of the parties or by any indulgence, forbearance whether as to payment time performance or otherwise.
7. Notwithstanding anything contained hereunder, our liability under this Guarantee shall be restricted to Rs. _____ and the guarantee shall remain in force upto 20__ unless a claim is lodged under this Guarantee within three months from the date of expiry of Bank Guarantee, your rights under the Guarantee shall be forfeited and we shall be relieved and discharged from all liabilities thereunder.

In witness whereof the said Surety subscribed and set its name and seal here onto ____ the day of 20 ____.

Place : _____
 Date : _____

ATTACHMENT - II**DETAILS OF EXPERIENCE**

Tenderer shall give information of similar works carried out during past five (5) years strictly as per the proforma given below.

Sl. No .	Full particulars of similar supply made by the Vendor	Supply Value	Completion time as stated in the Order	Actual Completion time	Year of completion	Name & Postal address of Client with Telephone/Fax No.
1	2	3	4	5	6	7

Certified that the above information is correct.

ATTACHMENT – III**DEVIATION STATEMENT (IF ANY)**

Please list clearly all Techno-commercial tender clauses against which a deviation / exception sought failing which it shall be deemed that the vendor has accepted the tender clause.

SL. NO.	TENDER REFERENCE (Page no., Clause No., Paragraph)	SUBJECT	DEVIATION / EXCEPTION PROPOSED

ATTACHMENT – IV**VENDOR'S INFORMATION**

<u>Sl no.</u>	<u>Description</u>	<u>To be filled in by the Tenderer</u>
1	Name1 (max. 35 char.)	
2	Name2 (max. 40 char.)	
3	Street/House No. (max. 50 char.)	
4	Street1 (max. 40 char.)	
5	Street2 (max. 40 char.)	
6	PIN Code (Postal Index No. e.g. "700001") (max. 6 char.)	
7	City/Place (e.g. "Kolkata" or "Dehradun") (max. 40 char.) or as the name of the city	
8	Country ("India" or "England" or as the name of country be)	
9	State (Name the state from where the office of Vendor/Supplier operates)	
10	First Tel. No. (With STD Code): (e.g. 033-22225280 or 022-66552814) (max. 30 char.)	
11	First Fax No. (with STD Code)	
12	Contact Person	
13	First Mobile No.	
14	E-mail Address) (max. 40 char.)	
15	PAN No. :	
16	GSTIN Registration No. :	
17	GSP Name (GST Suvidha Provider)	
18	Bank Name (max. 60 char.)	
19	Street (max. 35 char.)	
20	City (max. 35 char.)	
21	Branch (max. 40 char.)	
22	IFSC Code	
23	MICR Code	
24	Account No.	
25	Type of Account (Current, Savings, etc.)	

Seal and Signature of the Vendor



बामर लॉरी एण्ड कं. लिमिटेड
Balmer Lawrie & Co. Ltd.

REFINERY & OILFIELD SERVICES
21, Netaji Subhas Road,
Kolkata 700 001

TENDER DOCUMENT

FOR

FABRICATION, TESTING & SUPPLY OF
DECANTER MODULE WITH
MECHANICAL & ELECTRICAL WORKS
AND
DECANTED OIL TANK

Tender No.: ROFS/CAPEX/19-20/ENQ/15

Dated: 14.01.2020

Tender Due date & Time : 03.02.2020, 16:00 Hrs

NOTES:

- 1.0 Details of the item under this Schedule shall be read in conjunction with this note and corresponding Specifications, data sheets and Tender documents.
- 2.0 The tenderer should quote for all items in the Price Bid. The rates should be expressed in English both in figure and words. Where discrepancy exists between the two, rates expressed in words will prevail. Similarly, if there is any discrepancy between unit rate and total amount, the unit rate will prevail. All entries shall be in English language.
- 3.0 The rates should be quoted in the same units as mentioned in the tender schedule of quantities.
- 4.0 Every page of the tender document including annexure/enclosures shall be stamped and signed by the tenderer or his authorized representative thereby indicating that each and every page has been read and the points noted.
- 5.0 The Quantities of the item mentioned in the Schedule of Items are approximate and may vary altogether.

PRICE SCHEDULE

Tender No. ROFS/CAPEX/19-20/ENQ/15

Scope: FABRICATION, TESTING & SUPPLY OF DECANter MODULE WITH MECHANICAL & ELECTRICAL WORKS AND DECANter OIL TANK

Sl. No	Item Description	Unit	Qty	Unit Rate (Rs)	Total Amount (Rs)
A	Fabrication, assembly and Supply of Container Module of Size [20 ft (L) X 8 ft (W) X 9 ft (H)] with supply of all required materials as per Scope of Work.	Lot	1		-
B	Assembly & Installation of 1 no Decanter Centrifuge (Free issue by BL) inside the container module as per Scope of Work	Lot	1		-
C	Fabrication & Installation of 1 no Mild Steel Recovered Oil tank-5 KL capacity with supply of all required materials as per Scope of Work.	Lot	1		-
D	Mechanical & Piping Work as per Scope of Work of the tender	Lot	1		-
E	ELECTRICAL WORKS				
1	Supply & Laying of 4C X 20 sq. mm. FR 1.1 KV armoured shielded Power cable with Copper Conductor with saddles, saddles base & other accessories complete as required.	Mtr	10		-
2	Cabling from (Supply & Laying with Supply of FR 3 core x 2.5 sq. mm, 1.1 KV Armoured Cable with copper conductor with saddles, saddles base & other accessories complete as required.	Mtr	20		-
3	Cable Termination: Flameproof Termination of following Sizes of XLPE/PVC insulated armoured cables including supply of double compression type brass cable glands, lugs etc.				-
3.1	4 C X 20 sq. mm. FR 1.1 KV Shielded Armoured Copper Power cable	No	2		-
3.2	3 C X 2.5 sq. mm FR 1.1 KV Armoured cable with Copper conductor, XLPE/PVC insulated, taped PVC innersheathed, armoured, PVC outersheathed cable	No	10		-
4	Earthing of Equipment, Panels by Single core Aluminum cable/galvanized (Hot Dip) MS flat/ 6 swg GI wire as required and termination of all earthing lead to terminal earth bus bar of galvanized (Hot Dip) MS flat 50 X 6 mm to be fixed on wall including providing drilled holes on the bus bar complete with GL bolts, nuts, washers, spacing insulators, welding etc. as required.	Lot	1		-
					-

BIDDERS
NOT TO
QUOTE
HERE

	Installation of Free Issue Flameproof Items with fabrication of necessary mounting structure for fixing on container wall/roof.				-
5	30 KW VFD Starter Panel of Decanter Centrifuge	Nos	1	BIDDERS NOT TO QUOTE HERE	
6	Local Control Station for Motor	Nos	1		
7	40W FLP Tube Light Fixture/26 Watt Well glass fittings	Nos	2		
8	16 Amps ON/OFF Flame Proof Switch Isolator	Nos	2		
9	4 way Lighting junction box	Nos	1		-
	TOTAL BASIC (A+B+C+D+E) WITHOUT GST				-
	Add for GST (bidder to specify %)			18%	-
	GRAND TOTAL WITH GST				-
	GRAND TOTAL WITH GST in Words: (Please type)				

Note:

- 1) All Supply items shall include cost for P&F, transportation & transit insurance
- 2) The quantities mentioned above may change or may be deleted, however the rates should remain firm.
- 3) Please fill up, print, sign, stamp, scan and upload the above mentioned Price Bid in bid common form in e-procurement portal of Balmer Lawrie.
- 4) If GST% varies for different items, it will be paid as applicable.

Name of the Bidder:**Name & Signature of Signatory:****Seal of the Company:****Date:****Place:**

THE DRAWING IS THE PROPERTY OF BALMER LAWRIE & CO. LTD. AND SHALL NOT BE DISCLOSED TO OR USED WITHOUT THE WRITTEN CONSENT OF BALMER LAWRIE & CO. LTD.

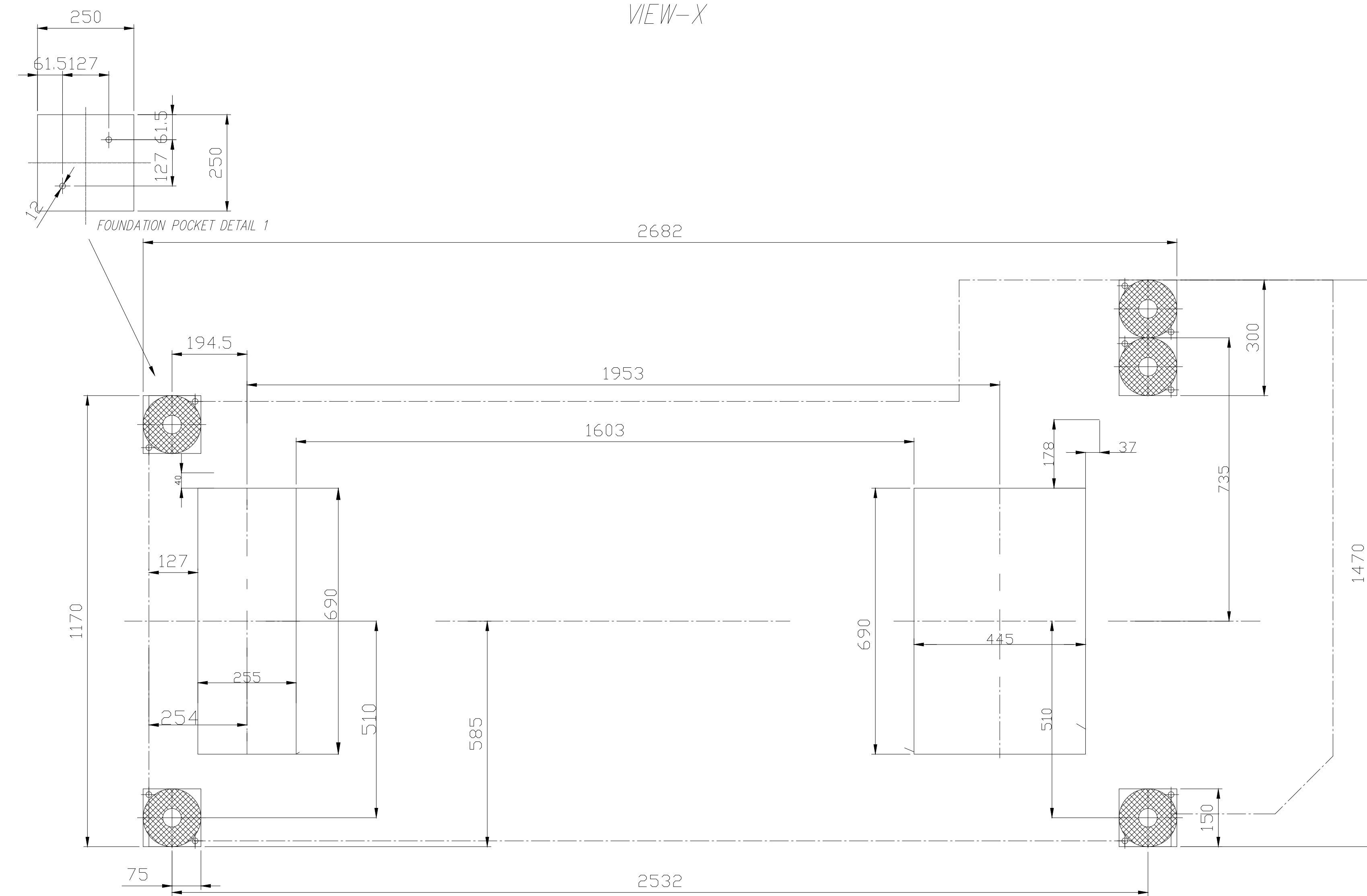
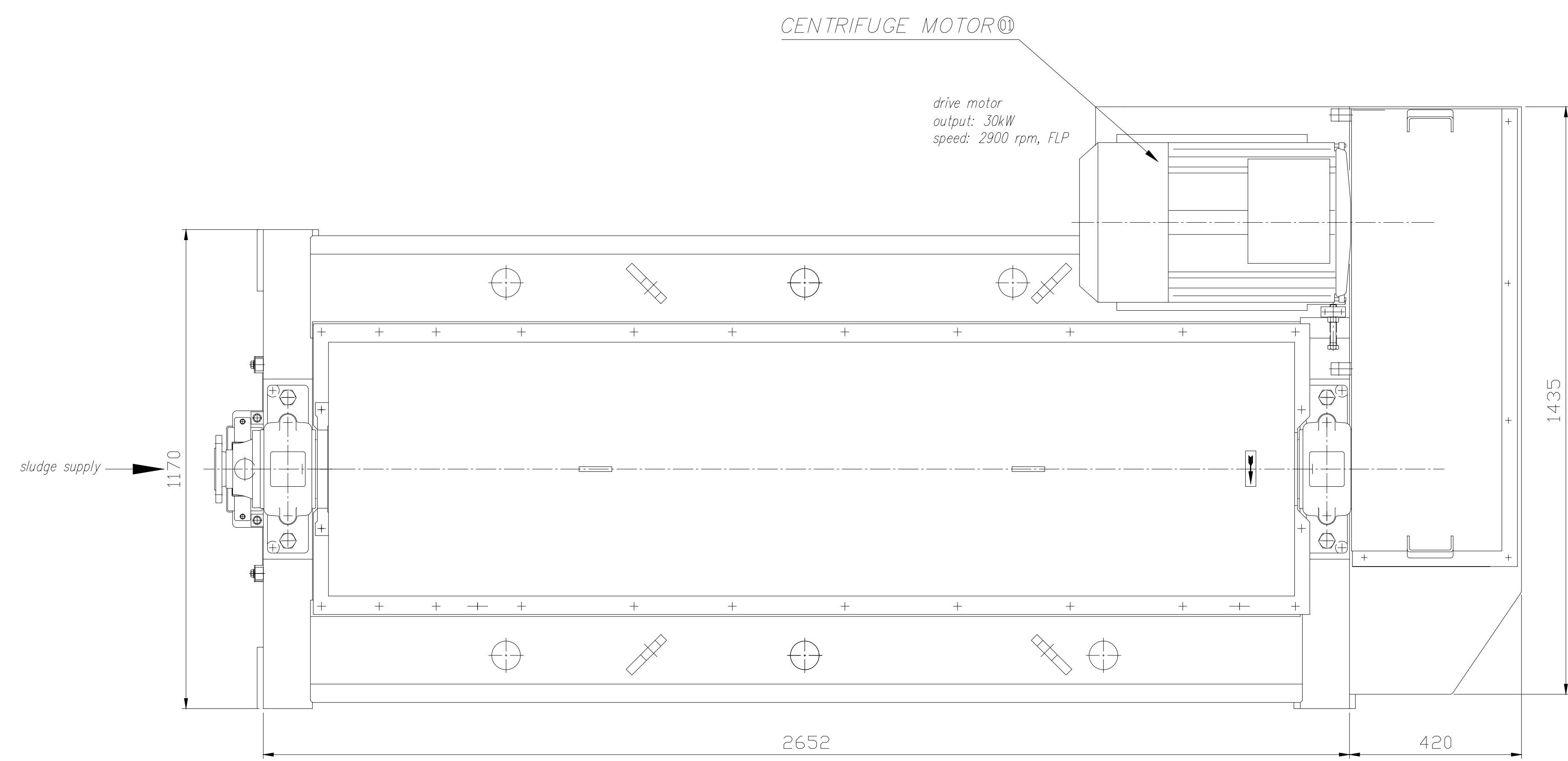
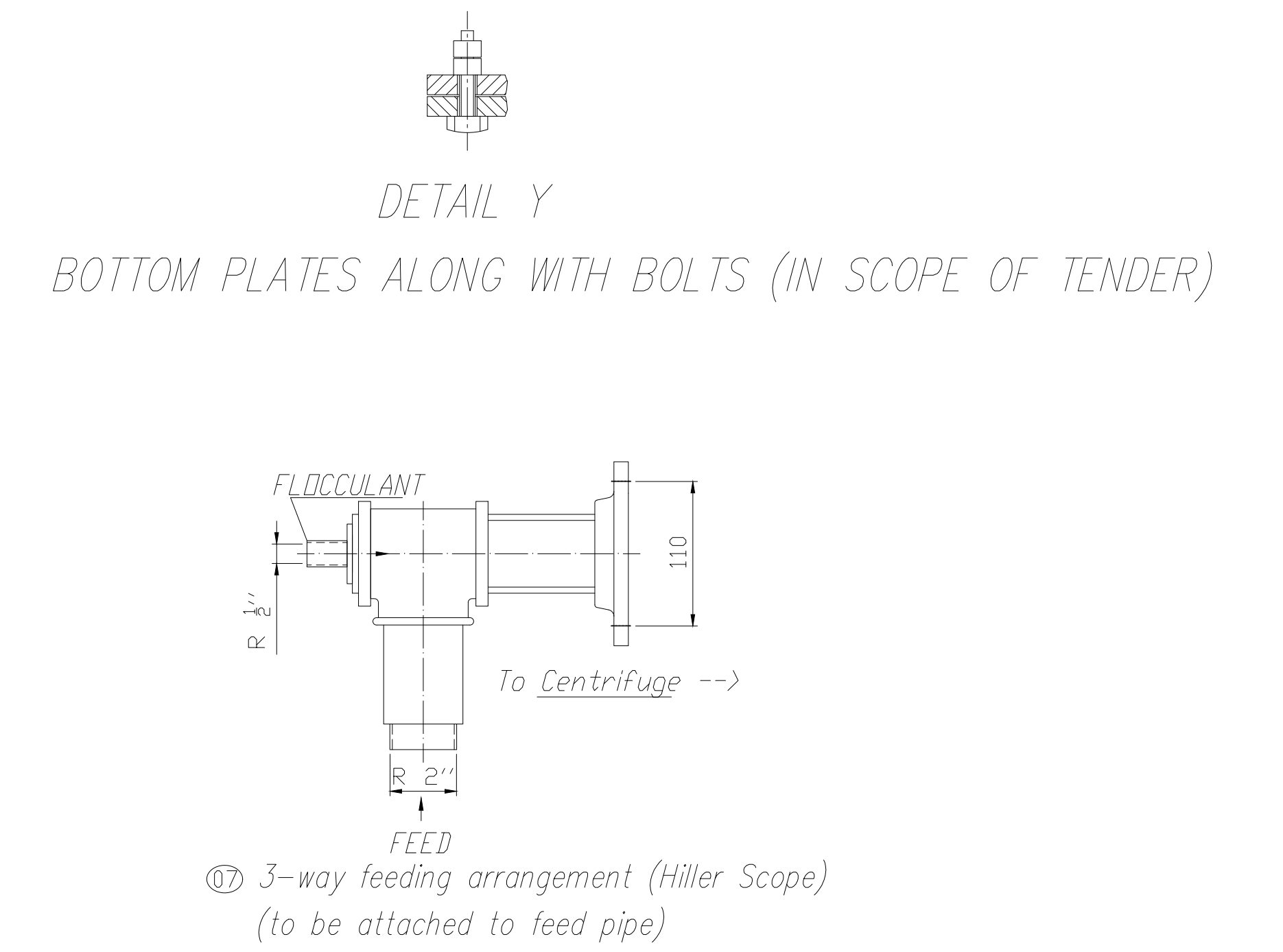
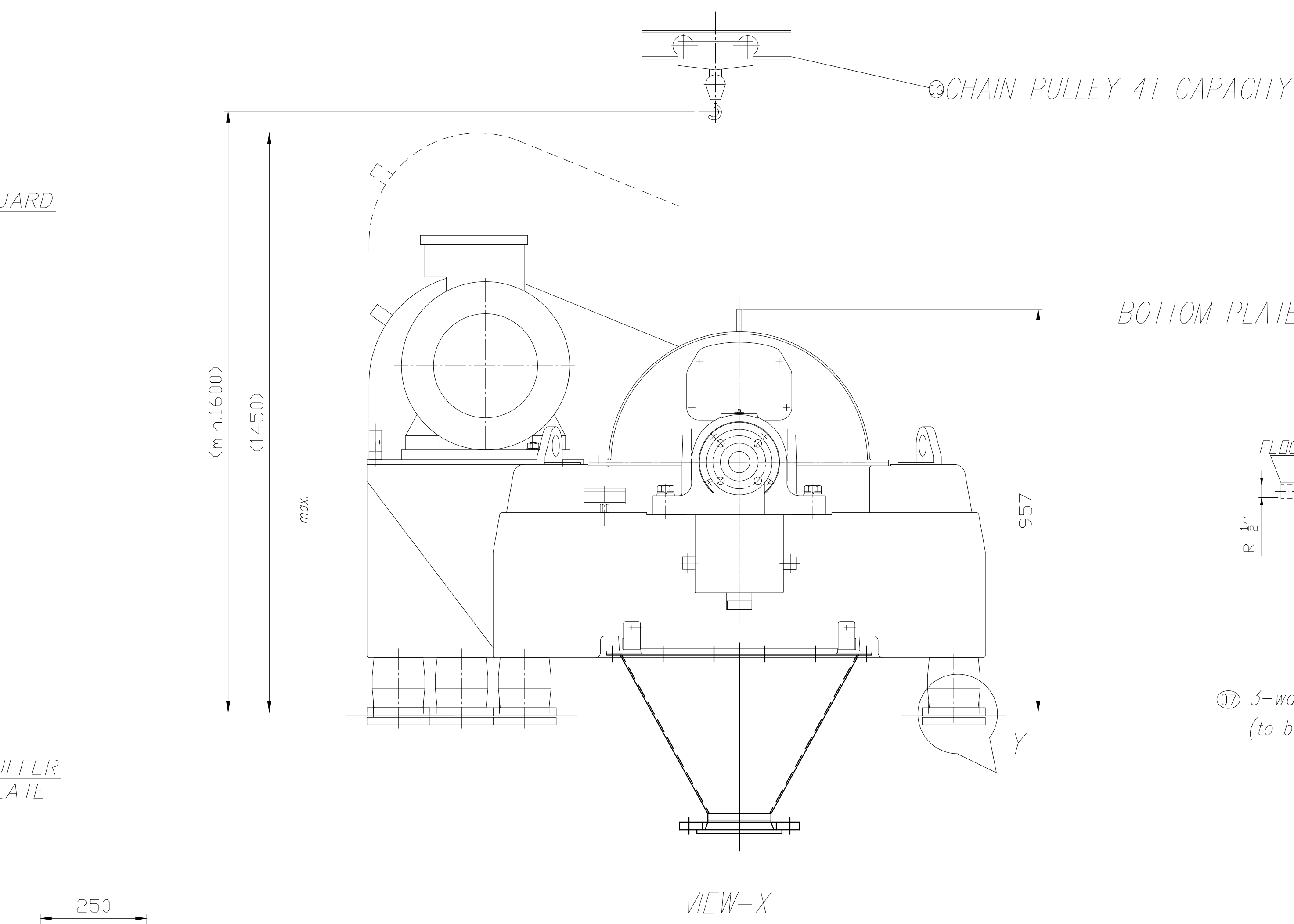
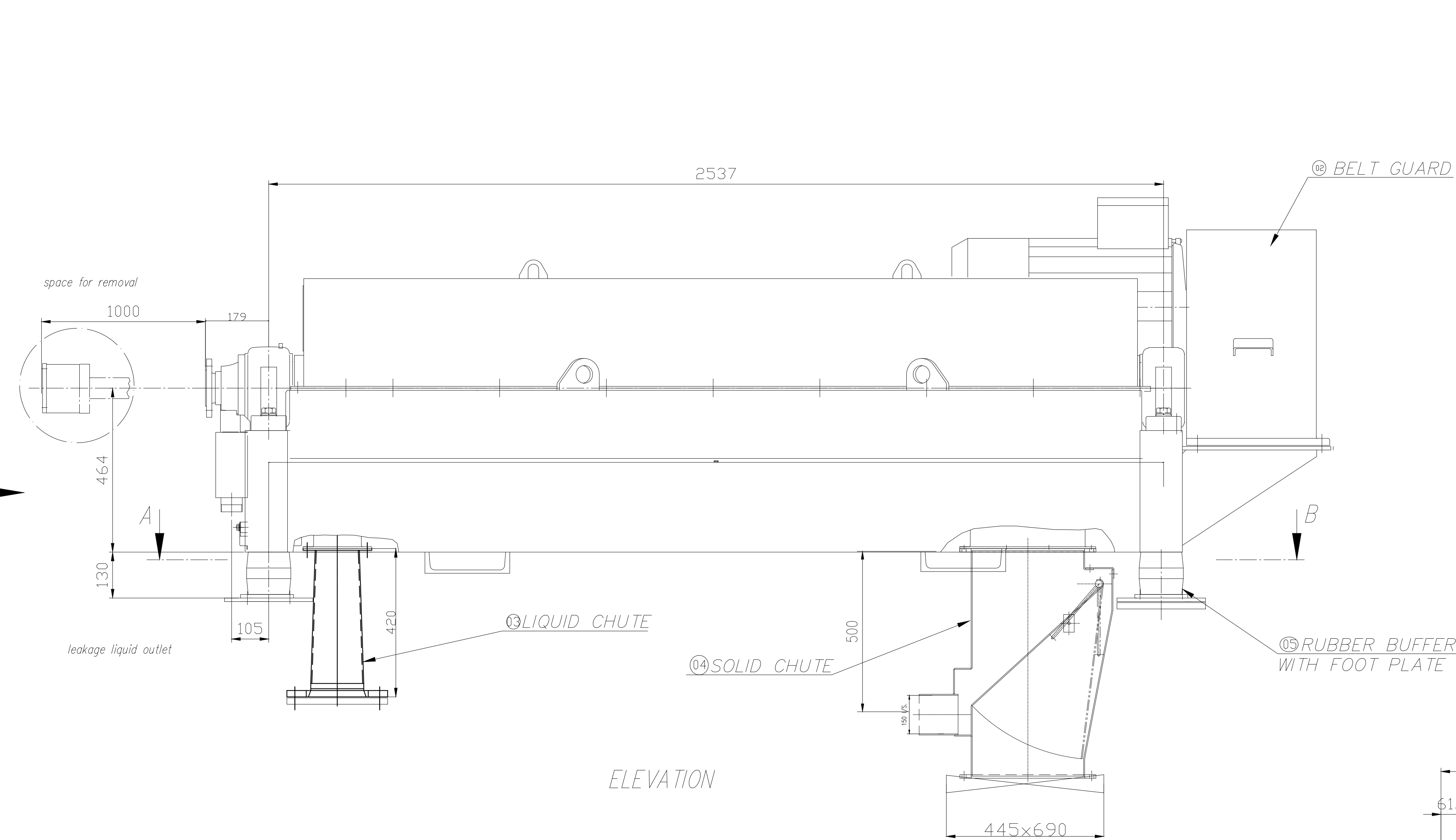

NOTE:
FOOT PLATES TO BE RESTED ON
PAD PLATES ON STRUCTURAL
CROSS BEAMS OF CONTAINER

TENDER DRAWING

REV	ATE	DESCRIPTION	JOB NO.	SCALE :
				NTS

PREPD.	KD	09/01/2020
CHECKED	SAJ	09/01/2020
APPD.	AB	09/01/2020

Balmer Lawrie & Co. Ltd.
Refinery & Oilfield Services

CLIENT :

TITLE : GA DRAWING OF DECANTER CENTRIFUGE		
DRAWING NO. ROFS/BLABO - 01/DCNTER	SHEET NO. 1 OF 1	REV. 00

THE DRAWING IS THE PROPERTY OF BALMER LAWRIE & CO. LTD. AND SHALL NOT BE DISCLOSED TO OR THIRD PARTY, COPIED OR USED WITHOUT THE WRITTEN CONSENT OF BALMER LAWRIE & CO. LTD.

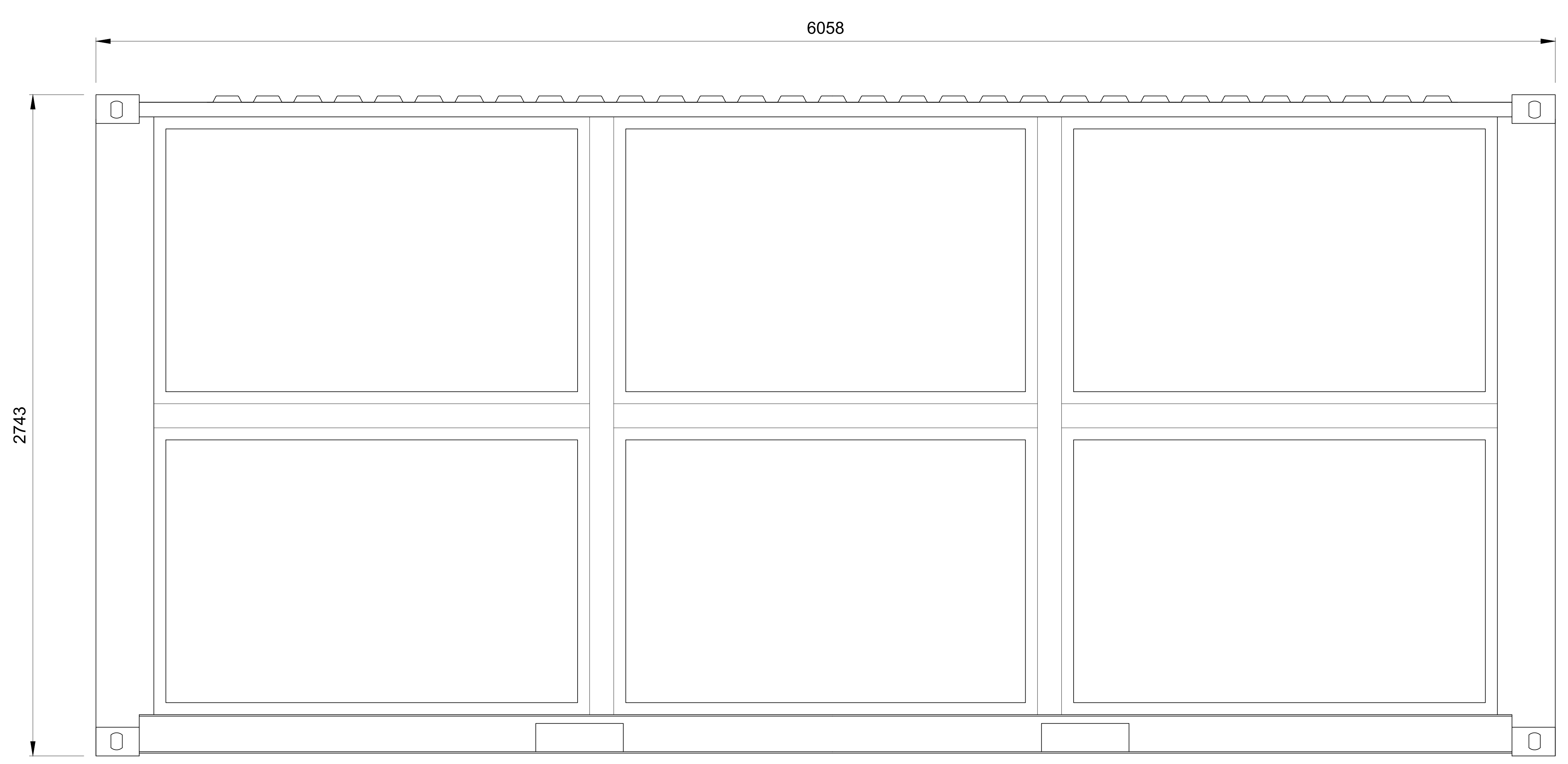

SIDE ELEVATION

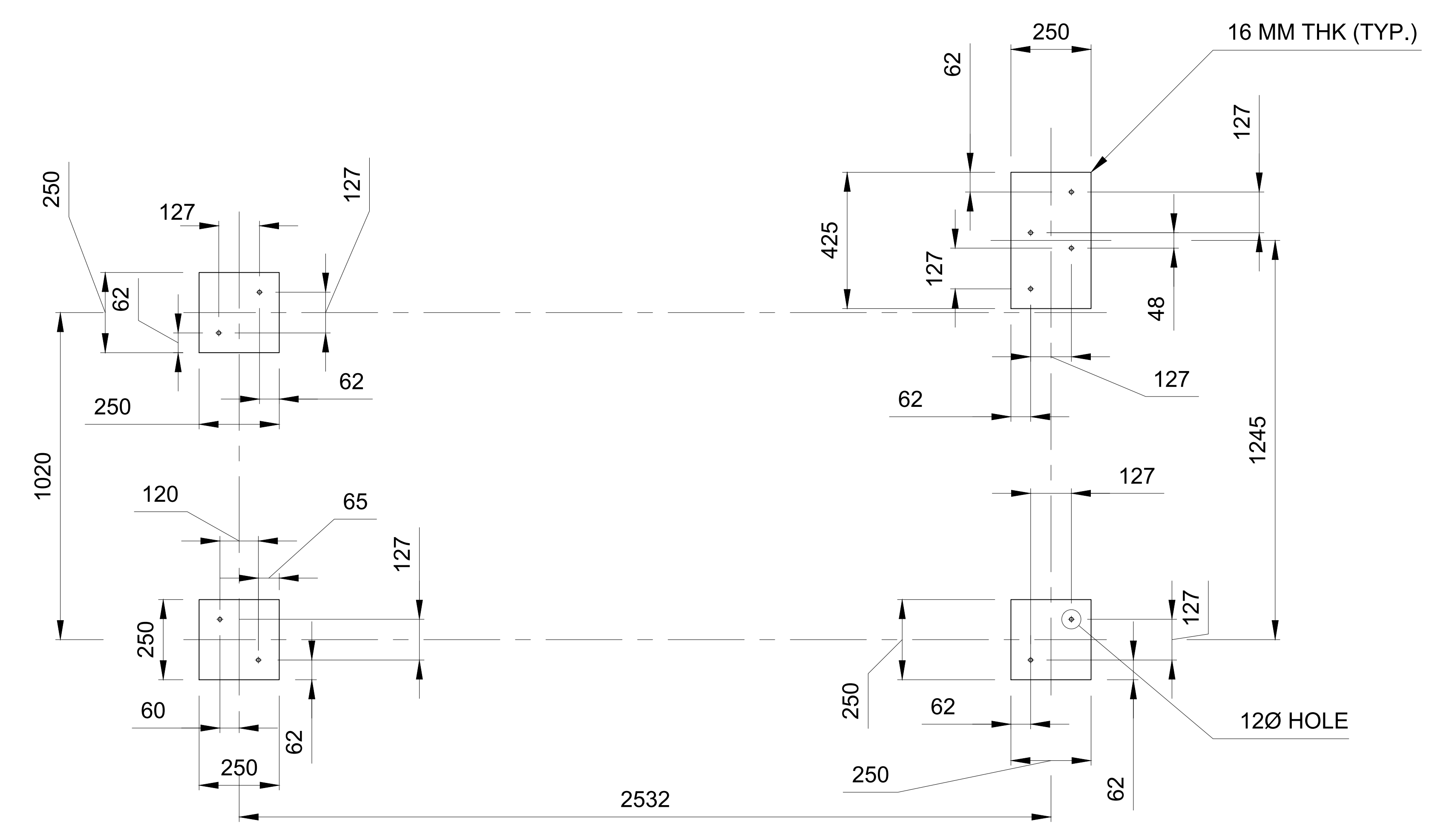

PLAN AT BASE PLATE LEVEL

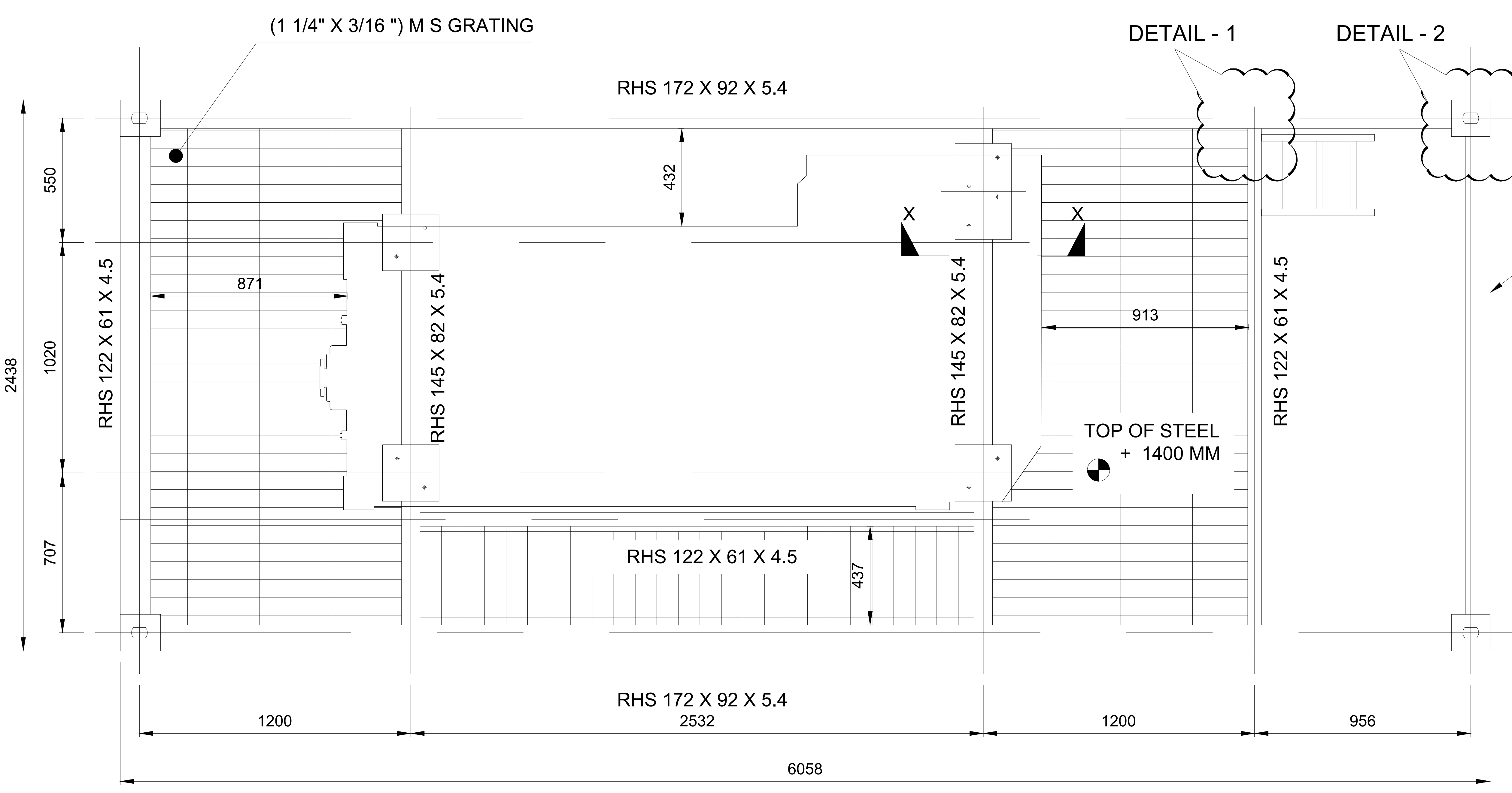

FRAMING PLAN
CONTAINER MODULE SIZE [(20'(L) X 8'(W) X 9' (H)]

DETAIL - 1

DETAIL - 2

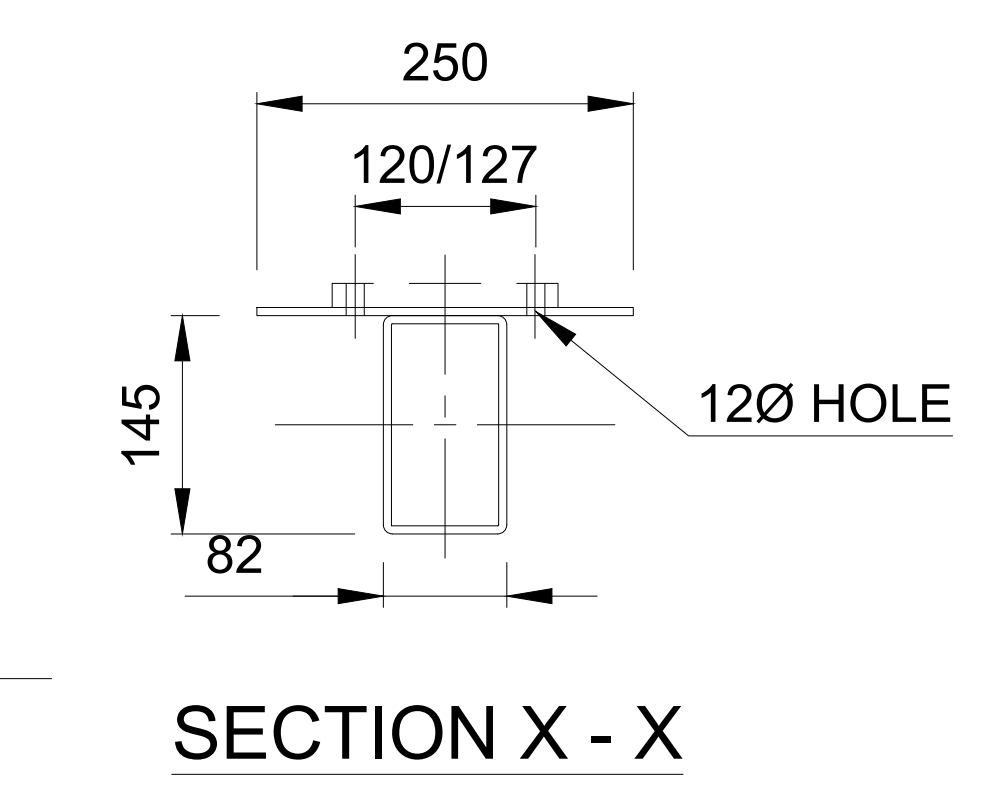

SECTION X - X

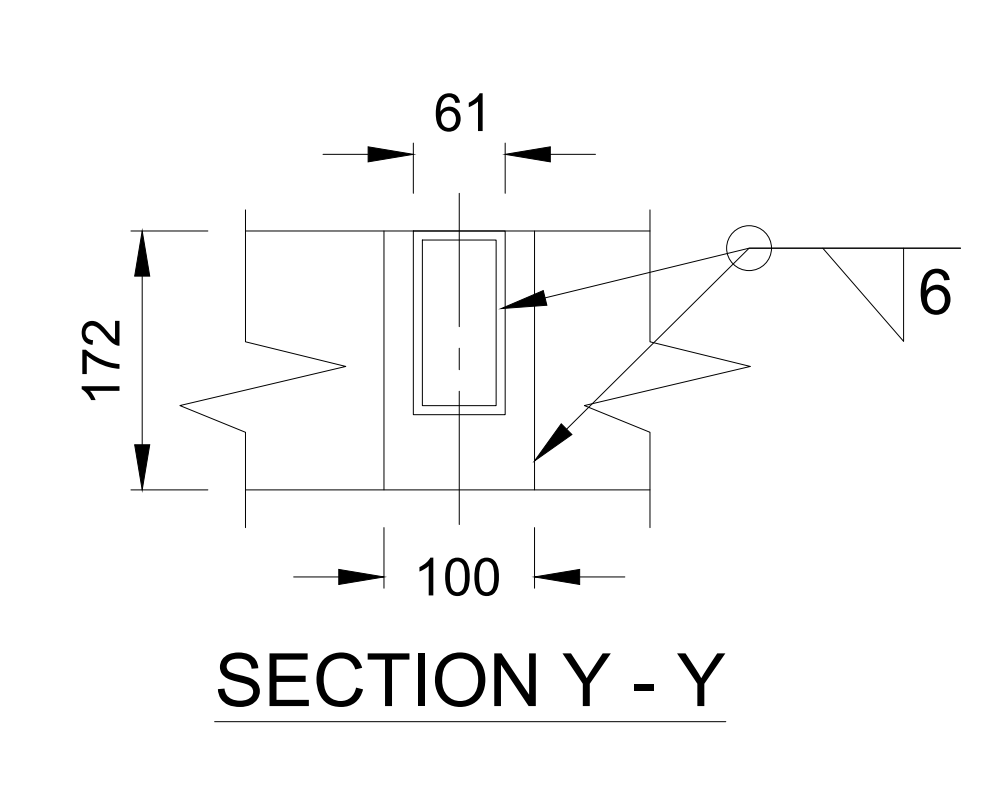

SECTION Y - Y

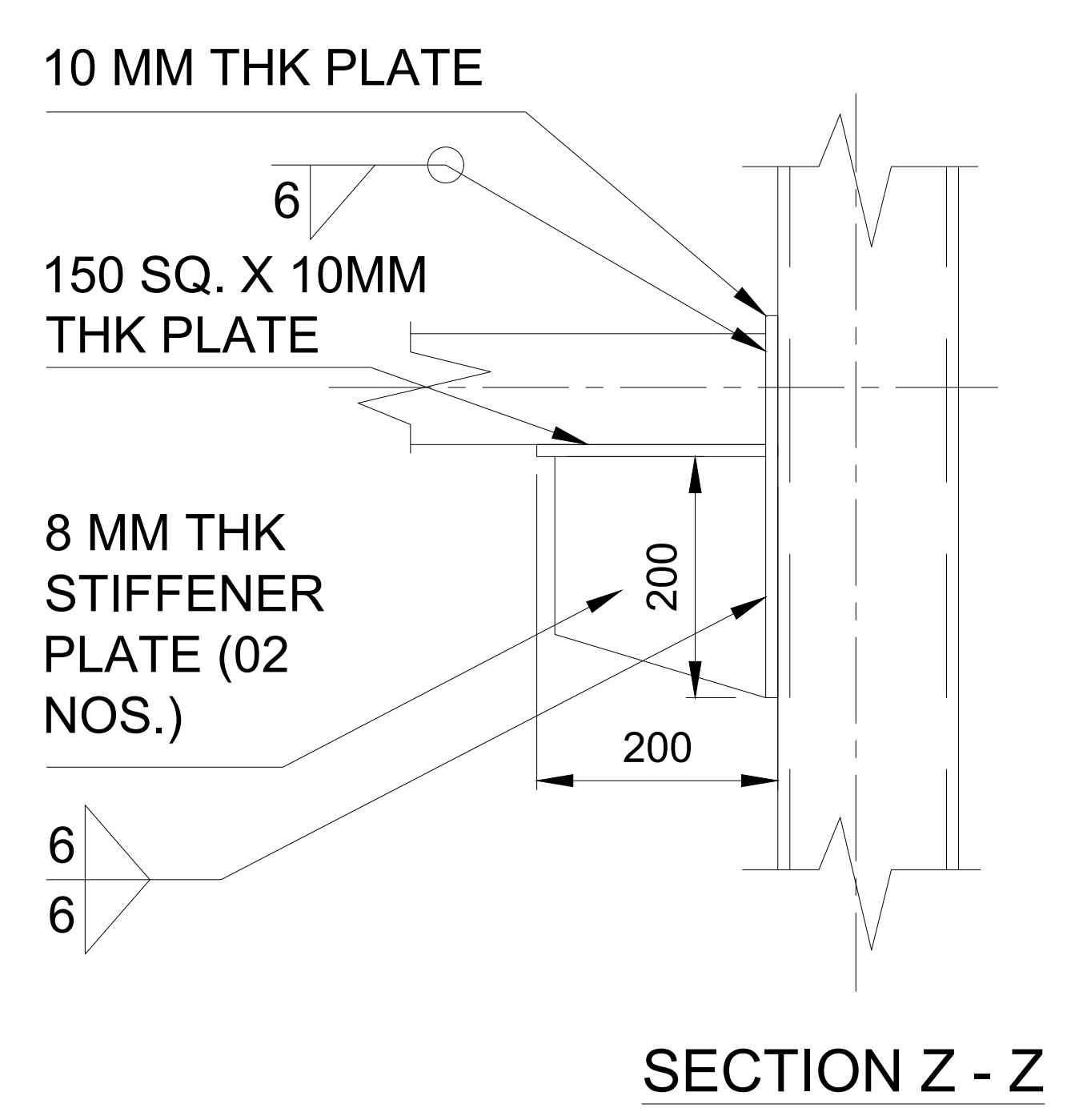

SECTION Z - Z

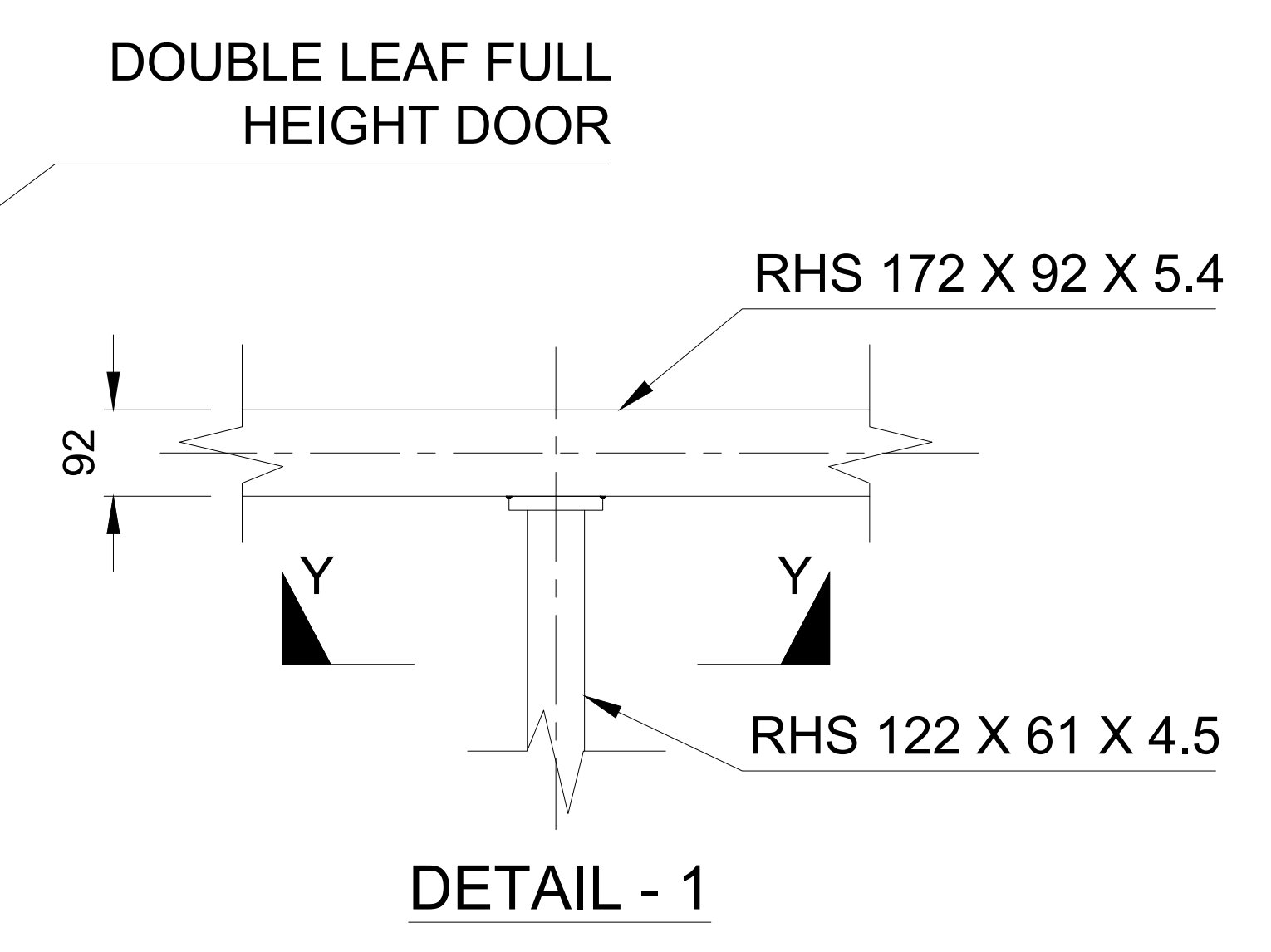

DETAIL - 1

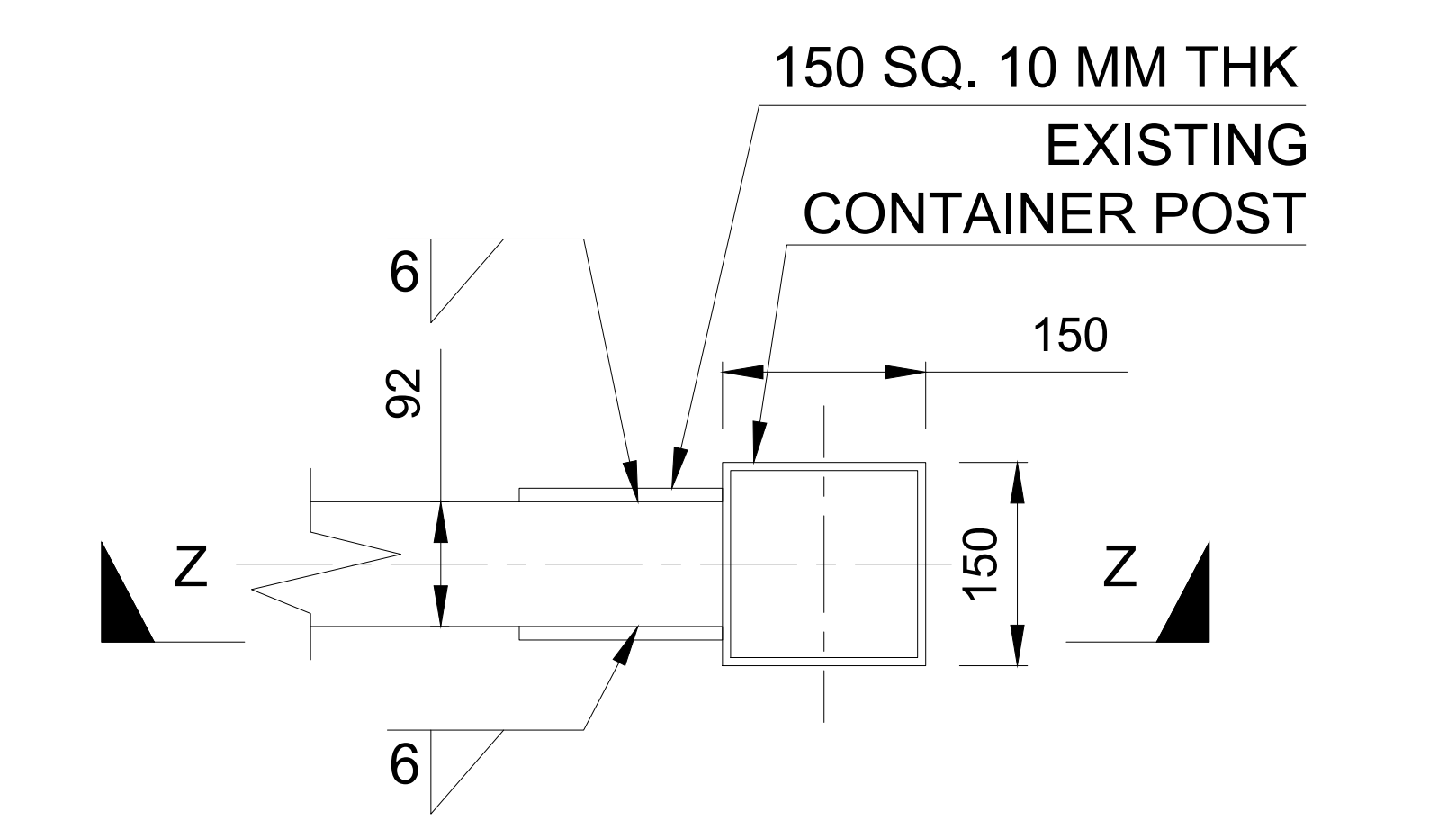

DETAIL - 2

TENDER DRAWING

REV	ATE	DESCRIPTION	JOB NO.	SCALE :
				NTS

PREPD.	KD	09/01/2020
CHECKED	SAJ	09/01/2020
APPD.	AB	09/01/2020



CLIENT :

TITLE : STRUCTURAL ARRANGEMENT FOR MOUNTING OF DECANter CENTRIFUGE

DRAWING NO. ROFS/BLABO - 1/DECANter/02	SHEET NO. 1 OF 1	REV. 00
---	---------------------	------------

THE DRAWING IS THE PROPERTY OF BALMER LAWRIE & CO. LTD. AND SHALL NOT BE DISCLOSED TO A THIRD PARTY, COPIED OR USED WITHOUT THE WRITTEN CONSENT OF BALMER LAWRIE & CO. LTD.

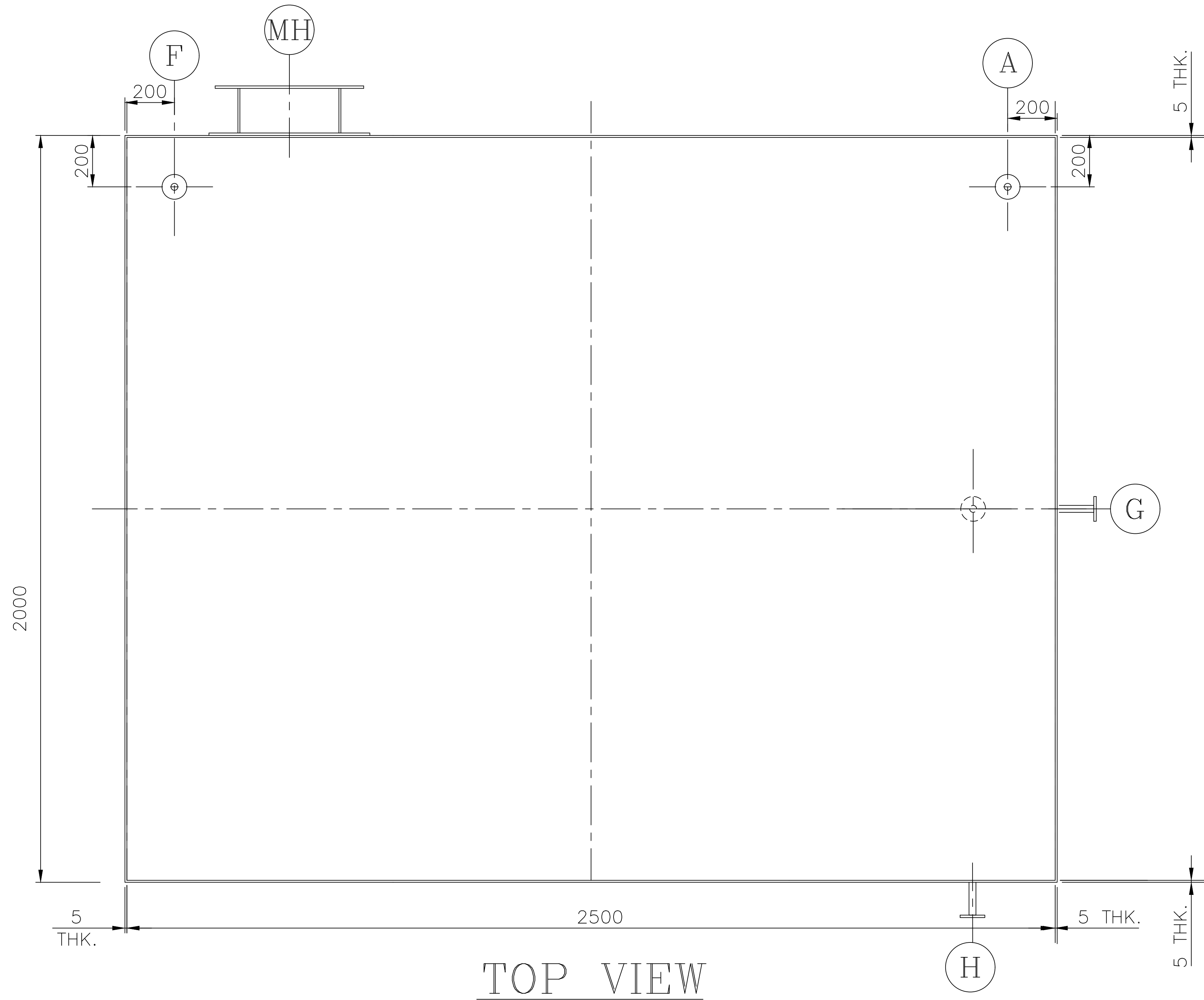
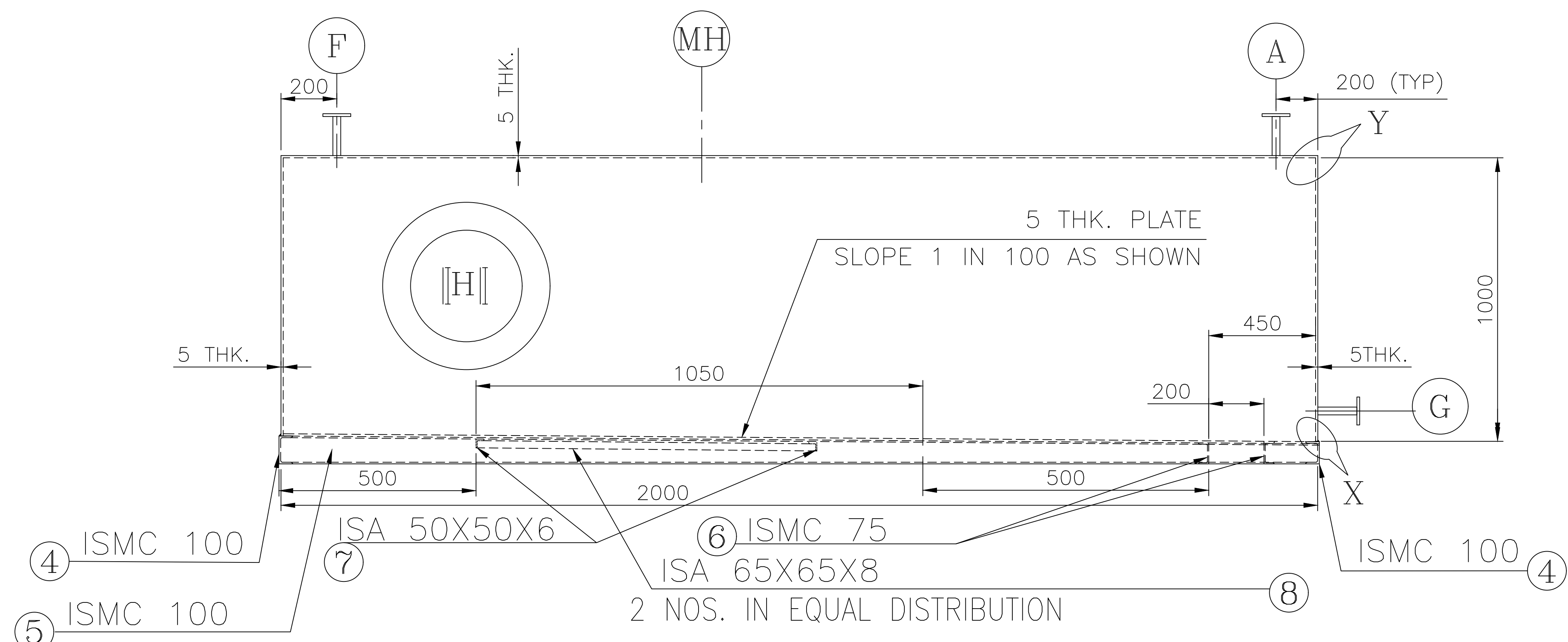

TOP VIEW

LUBE OIL DAY TANK. TAG NO.:T-105, 106, 107 & 108								
NOZZLE SCHEDULE								
MARK	QTY.	SIZE	RATING	TYPE	SCH	PROJ.	SERVICE	REMARKS
A	1	6"	150#	SORF	SCH40	6"	OIL INLET	
MH	1	18"	*	-	-	8"	MANHOLE	
F	1	3"	150#	SORF	SCH40	6"	VENT	
G	1	3"	150#	SORF	SCH40	6"	OIL OUTLET	
H	1	2"	150#	SORF	SCH40	6"	DRAIN	

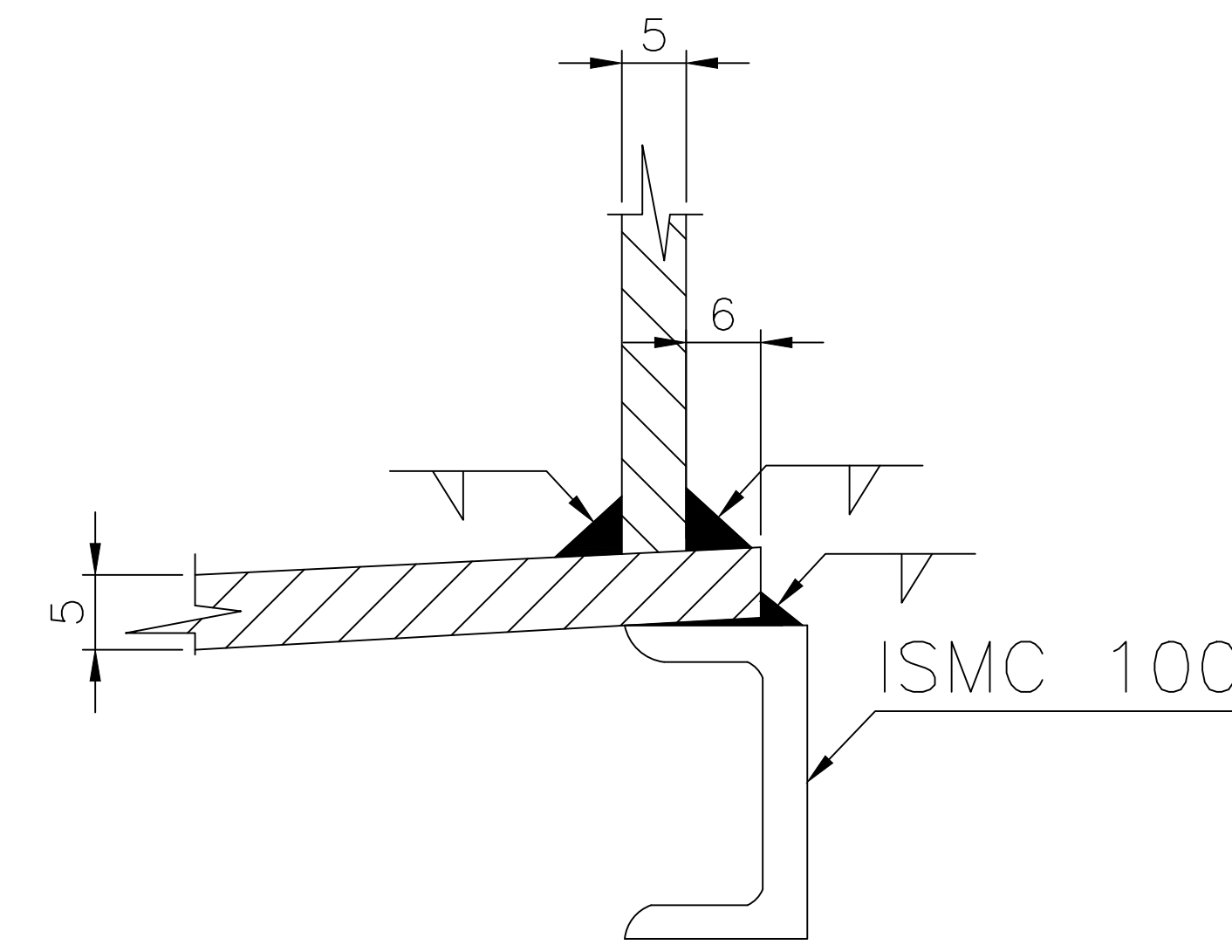

DETAIL OF 'X'

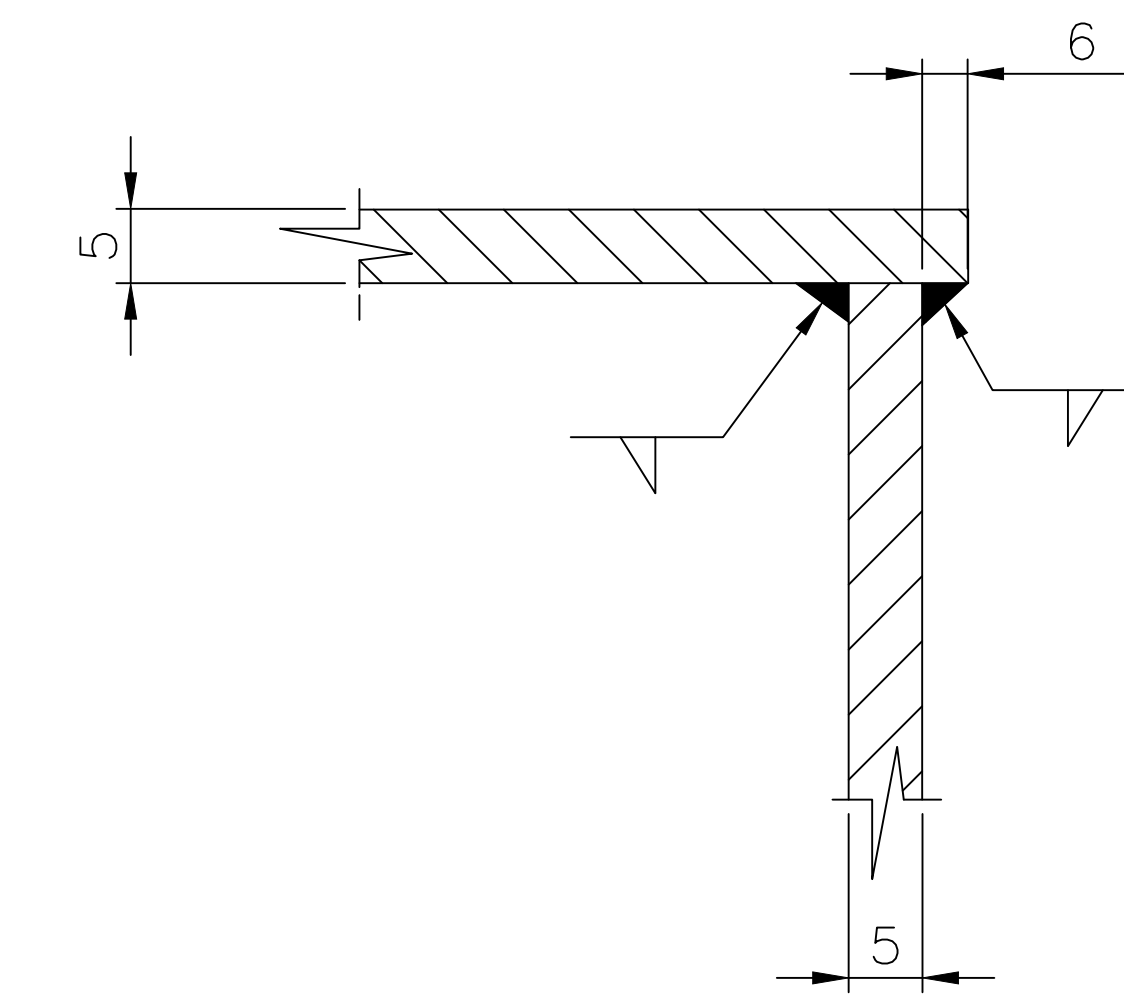

DETAIL OF 'Y'

8	ISA 50X50X6	
7	ISA 50X50X6	
6	ISMC 75X40	
5	ISMC 100X50	
4	ISMC 100X50	
3	SLOPE PLATE	5
2	TOP PLATE	5
1	SIDE PLATE	5
SL. NO.	ITEM	PLATE THICK.
LIST OF MATERIAL		

NOTE : THE TANKS SHALL BE MOUNTED ON ANGLE/CHANNEL FRAME AT THE BOTTOM TO ACCOMODATE THE BOTTOM PLATE SLOPE.

ALL NOZZLES TO BE PROVIDED WITH 6 mm THK. PAD PLATE

DESIGN DATA :

CODE :	:	API 650
SHELL	:	IS: 2062
MANHOLE NECK	:	IS: 2062
MANHOLE FLANGES	:	IS: 2062
FLANGES UPTO 250mm	:	ASTM-A105
BOLTS & NUTS	:	ASTM A193M/A194
STRUCTURE	:	IS: 2062
GASKETS	:	SPIRAL WOUND GASKET AS PER API 601 UP TO 24"
MANHOLE	:	IS: 2062

PAINTING :

AS PER TECHNICAL SPECIFICATION.

REV	ATE	DESCRIPTION	JOB NO.	SCALE :
				NTS

PREPD. KD 09/01/2020
 CHECKED SAJ 09/01/2020
 APPD. AB 09/01/2020

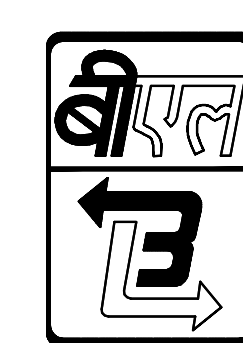

Balmer Lawrie & Co. Ltd.
 Refinery & Oilfield Services

CLIENT :

TITLE : GA DRAWING OF RECOVERED OIL TANK. (CAP 5 KL)

DRAWING NO. ROFS/BLABO - 1/ROT/03	SHEET NO. 01 OF 01	REV. 00
--------------------------------------	-----------------------	------------