



**SBU – Industrial Packaging,**  
**5, J. N. Heredia Marg, Ballard Estate,**  
**Mumbai- 400001, India**  
**Tel. No. 091 - 022 –66258215/66258208**  
**Fax No. 091 - 022– 66258200**

**NOTICE INVITING TENDER**

**Tender No. 0100LC1452 DTD. 08.08.2019**  
**Due date of Tender: 19.08.2019 Till: 15:00 HRS**  
**Opening of Technical Bid: 19.08.2019 after 15:15 HRS**

Online Two Bid e-Tender is invited from vendors for “Supply of End Forming Die Set (2 Nos.)” for our Barrel Manufacturing Plant at Silvassa (UT of Dadra Nagar & Haveli) through Balmer Lawrie e. procurement Portal <https://balmerlawrie.eproc.in>

**The bidder should be registered in Balmer Lawrie Web Portal through C1 India for online e.bidding.**

**Contact details**

<b>Balmer Lawrie &amp; Co.Ltd.</b> SBU-Industrial Packaging, 5, J .N. Heredia Marg, Ballard Estate Mumbai – 400 001.	<b>C1 India Pvt.Ltd.</b> 603,Coral Classic,20 <sup>th</sup> Road, Near AmbedkarPark,Chembur Mumbai-400 071
Contact Persons:  1.Mr.Tushar Ingale Email id – <a href="mailto:ingale.td@balmerlawrie.com">ingale.td@balmerlawrie.com</a> Mobile – 9769015541  2.Mr.Bhavik Oza Email id - <a href="mailto:ozabg@balmerlawrie.com">ozabg@balmerlawrie.com</a> Mobile – 9725812549	1. Mr. Ujwala Shimpi, (022) 66865608 Email – <a href="mailto:ujwala.shimpi@c1india.com">ujwala.shimpi@c1india.com</a> (Mumbai / Monday - Friday) 2. Mr. Tirtha Das, Mob +91 -9163254290 Email - <a href="mailto:tirtha.das@c1india.com">tirtha.das@c1india.com</a> (Kolkata / Monday -Friday) 3.Mr.CH.Mani Sankar (Chennai),+91-6374241783 Email– <a href="mailto:chikkavarapu.manisankar@c1india.com">chikkavarapu.manisankar@c1india.com</a> (Chennai / Monday -Saturday) 4.Helpdesk Support (Kolkata) Email - <a href="mailto:blsupport@c1india.com">blsupport@c1india.com</a> - (Monday – Saturday) +91 -8017272644 <b>Escalation level – Mr.Tuhin Ghosh,Mob.+91-8981165071 Email – <a href="mailto:tuhin.ghosh@c1india.com">tuhin.ghosh@c1india.com</a></b>

## **1. Introduction**

Balmer Lawrie & Co. Ltd is a Mini-Ratna-I Public Sector Enterprise under the Ministry of Petroleum & Natural Gas, Government of India along with its six joint ventures in India & abroad. Today it is a much-respected transnational diversified conglomerate with presence in both manufacturing and service sectors. Balmer Lawrie is a market leader in Steel Barrels, Industrial Greases and Specialty Lubricants, Corporate Travel and Logistic Services. It also has significant presence in most other business. It operates, viz, Performance Chemical, Logistic Infrastructures etc. In Industrial Packaging, we are the leading manufacturer of MS Drums, holding the largest market share in India. The Company has a distributed manufacturing base with factories in Chennai, Chittoor, Silvassa, Asaoti, Kolkata, Talaja and Vadodara. Our Plants are ISO Certified and conforms to Safety, Health and environment norms.

### **A. Instructions for bidders.**

1. Online Two bid [Pre-qualification Criteria & Price bid] e-Tenders are invited from vendors for "Supply of End Forming Die Set (2 Nos.)" at our Barrel Manufacturing Plant at Silvassa (UT of Dadra Nagar & Haveli) as per detailed specification contained in Annexure- I of this tender documents.
2. **Please Refer to Annexure – I for detailed Technical Specifications & Scope of Supply.**
3. The tender is invited in **Two-Bid System**. The tender document consists of **Pre-Qualification Criteria (Unpriced Bid) - Annexure-II, & Price Bid Annexure-III**. **Price Bids of those bidders shall be opened only who will satisfy all Pre-Qualification Criterion as written in Annexure- II.**
4. All documents required in the tender can be scanned and submitted online through appropriate forms as attached in the tender.
5. Important points to be noted

<b>5.1 Due date for submission of bids on Line</b>
--

<b>Date: 19.08.2019 till 15:00 hrs.</b>
---

All Bids are to be completed in accordance with tender requirements within the duration as mentioned.

The bidders are requested to bid online within the tender announcement date and tender closing date and time as mentioned in the tender document.

The term "**BL**" wherever mentioned in the tender document refers to "**Balmer Lawrie & Co. Ltd.**"

**BL would be the Purchaser/Owner for the tendered item.**

**The successful bidder will be the Supplier.**

BL reserves the right to accept any bid in full or part.

**This document is the Tender.**

**The Acceptance of the Order by the successful bidder will form the contract.**

6. Earnest Money Deposit (EMD) – As per Clause no. 1 & 2 of the Special Terms & Conditions of this Tender document.

- Micro and Small Enterprises (MSE's) with valid "Udyog Aadhar Memorandum" (UAM) number are exempted from payment of Earnest Money Deposit and eligible to participate and are also eligible for any other benefit applicable to MSE's mentioned in this tender document. Above benefit/s shall be extended only to MSE's whose UAM no. is registered with Central Public Procurement Portal (CPPP) and such MSE are required to submit a declaration for the same as per Annexure –VIII.
- Failure to submit aforementioned declaration by the bidder claiming above benefits will be treated as a non-MSE's bidder and such bid shall be cancelled accordingly.

**Response from registered / unregistered Vendors will be accepted through BL E-proc Portal.**

**Contractors, vendors, who are having unresolved issues, disputes, complaints, legal or court cases against the company and bidders with whom Balmer Lawrie have/had any dispute during the last 5 years whether the same has/had been subsequently settled or not, will not be eligible to participate/bid.**

The bidder may up-load necessary documents with the on-line bid or furnish in person or through courier / by post and the receipt of the same within the stipulated time shall be the responsibility of bidder. BL shall not take any responsibility for any delay or non-receipt of said documents. If any of the documents furnished by the bidder is found to be false / fabricated, the bidder is liable for black listing, forfeiture of the EMD, cancellation of work and criminal prosecution.

Unless otherwise agreed to in terms of the purchase order, the price shall be firm till execution of entire order.

**VENDOR UNDERTAKING [ON CO'S LETTER HEAD DULY SIGNED & RUBBER STAMPED]**

"WE HAVE STUDIED THE TENDER DOCUMENT CAREFULLY AND HAVE QUOTED OUR LOWEST RATE IN ACCORDANCE WITH THE TECHNICAL SPECIFICATIONS, TERMS & CONDITIONS AND SPECIAL TERMS & CONDITIONS AS LAID DOWN IN THE TENDER DOCUMENT. WE ALSO CONFIRM TO HAVE ACCEPTED ALL TERMS & CONDITIONS AND SPECIAL TERMS & CONDITIONS."

**SIGNATURE OF BIDDER WITH STAMP**

**7. Corrigendum to tender:**

The bidder has to keep track of any changes by viewing the addendum / Corrigendum's issued by the Tender Inviting Authority on time-to- time basis in the E-Procurement platform. The Company calling for tenders shall not be responsible for any claims/problems arising out of this.

**8. Format of Tender Document**

Tender Documents consist of:

- A. Instruction for bidders
- B. Special Terms & Conditions
- C. General Terms & Conditions
- D. Annexure- I – Scope of Supply/Work
- E. Annexure- II – Prequalification Criteria
- F. Annexure- III Price Bid.
- G. Annexure -IV - Conditions for Online Bid submission
- H. Annexure- V – Format for Bank Guarantee
- I. Annexure- VI – GST Compliance
- J. Annexure VII – Details of Vendor
- K. Annexure VIII- CPPP Declaration format for the MSE bidders
- L. Annexure IX – Terms & Cond. For submission of On Line EMD amount
- M. Annexure X - List of Officers designated for releasing Payments.

The bidder is expected to examine the Tender documents, including all instructions, forms, General Terms & Conditions, Special Terms & Conditions, Technical Specifications and other documents and to fully familiarize itself with the requirements of the bidding documents. Failure to furnish all the information required by the Bidding Documents or the submission of a bid not substantially responsive to the Bidding Documents in every respect may result in the rejection of the Bid.

**9. Late Bids**

No bidding is admissible in the E.Proc platform after the bid closing time /date.

**10. Bid Validity**

The offer shall remain valid for a period of **three** months from the date of opening of the Price Bid.

**11. Bid Rejection Criteria**

A bid may be rejected

If the bidder fails to send the Earnest Money Deposit (EMD) amount within the bid due date.

If deviations from the terms mentioned in the document affects in any way the scope, quality and performance.

If Conflict of interest between the bidder and the Company is detected at any stage.

**12. Clarifications**

Clarifications that the Bidder needs to have on the tender specification can be sought from BL within one week from the date of issue of this enquiry.

All clarifications shall be by e-mail (*Only email queries shall be replied*)

**13. Opening of Price Bid**

The Price Bid of Bidders will be opened on the due date.

**14. Complete Scope of Work**

The complete scope of work has been defined in Annexure-I of the tender document. Only those bidders who take responsibility and bid for the complete scope of work may be considered for further evaluation

**15. Tender Documents and Deviations**

It is expected that bidders will submit bids based strictly on the terms and conditions and specifications contained in the bidding documents and will not stipulate any deviations. **Deviation from technical specifications, as given in the Tender Document-Annexure – I, would invite immediate dis-qualification from further consideration of the bid.**

**16. Preparation and submission of Tender Documents**

The bidders are required to fill the tender document in a format as outlined below in the E.Proc platform:

**a. Price Bid (Annexure- III is Price Bid)**

The lowest bidder will be decided on the **Nett delivered Price on Composite basis** in Rupee, for the item mentioned in the scope of supply. Duties, levies charges either as % or value.

**Price bid should be filled on line as per the format provided (Annexure- III).**

**b. After submission of EMD and bid online, the bidders are requested to submit the hard copies of necessary documents (which cannot be uploaded) at our Ballard Estate Office at 5, J.N.Heredia Marg, Ballard Estate, Mumbai-400 001 before due date & time.**

**B. SPECIAL TERMS & CONDITIONS.**

**1. Earnest Money Deposit (EMD) : Rs.15000.00 (Rs. Fifteen Thousand only)**

EMD amount is to be paid online as per Annexure –X in tender documents. Cheque and any other form of payment are not acceptable towards EMD. EMD will be refunded online to bidders account from which they paid the EMD, after finalization of tender. For accepted bidders, EMD of successful bidder can be adjusted towards Security Deposit against the Purchase order placed on them. EMD will carry no interest. Linking with earlier transactions/adjustments with pending bills or any other amount payable by the Company is not allowed.

Micro and Small Enterprises (MSE's) with valid **"Udyog Aadhar Memorandum" (UAM)** number are exempted from payment of Earnest Money Deposit and eligible to participate and are also eligible for any other benefit applicable to MSE's mentioned in this tender document. Above benefit/s shall be extended only to MSE's whose UAM no. is registered with Central Public Procurement Portal (CPPP) and such MSE are required to submit a declaration for the same as per Annexure –VII.

- a) OFFERS RECEIVED WITHOUT EMD WILL BE REJECTED
- b) For the successful bidder, the EMD will be refunded only after they submit the necessary Security Deposit against the work order placed on them. EMD will carry no interest.

- c) For the unsuccessful bidders, the EMD will be refunded only after the successful bidder has accepted the Purchase order and the acknowledgement of the same has been received by BL.
- d) Linking of EMD amount with earlier transactions / adjustments with pending bills or any other amount payable by the company is not allowed.

**2. EMD is liable to forfeiture in the event of:**

- a) Withdrawal of offers during validity period of the offer
- b) Non acceptance of orders by the bidder within the stipulated time after placement of LOI / order
- c) Any unilateral revision made by the bidder during the validity period of the offer
- d) Non execution of the prescribed documents after acceptance of the contract
- e) Non submission of Security Deposit.

**3. Security Deposit (SD)**

Security Deposit amount of 5 % of the basic order value to be deposited by the successful Bidder in the form of Pay order / Demand Draft in favour of Balmer Lawrie & Co. Ltd, payable at Mumbai.

The Security Deposit may be submitted as Bank Guarantee by a **Scheduled Indian Bank** within 15 days of receipt of the Purchase Order. **Security Deposit can also be made directly to our Standard Chartered Bank (Account No. 222-0-526803-6, NEFT Code - IFSC "SCBL0036046) through electronic transfer and proof of transfer of funds deposited with us.**

The Security Deposit if paid by Pay Order/Demand Draft shall bear no interest and shall be refunded through Bank transfer to successful bidder, only on successful delivery/Commissioning of the tendered item and

All sums of compensation or other sums of money as determined, if any, payable by the bidder may be deducted from the Security Deposit.

**4. Security deposit is liable to forfeiture in the event of:**

- a) Non-Supply after Acceptance of Purchase Order.
- b) Successful Bidder fails to deliver the item as per the terms & condition of the Purchase Order.
- c) Successful Bidder violates the tender conditions.
- d) If the performance of the bidder is found to be unsatisfactory

**5. Period of Contract – Material to be delivered, Installed & Commissioned within **12 weeks** from the date of Purchase Order.**

**6. Payment Terms:**

Our payment terms are as follows:

1. 50% of total value of supplies as advance against submission of equivalent bank guarantee within 10 days after acceptance of purchase order & 40 % of the total value of supplies along with applicable taxes within 15 days after delivery of material at our Silvassa Plant. **OR** 90% of the total value of supplies along with applicable taxes after delivery at our Silvassa Plant & submission of bill within 15 days from Mumbai.
2. For Installation and Commissioning part – 90 % will be released after successful erection & commissioning at Silvassa Plant within 15 days.

3. 10% of the total order value - will be retained as performance guarantee & will be released after 12 months from date of commissioning

**Central Government vide Notification No.50/2018 dated 13th September 2018, has made TDS provision applicable under GST Law on all payments affected by Public Sector Undertaking (PSU) w.e.f 1st October 2018. BALMER LAWRIE being a PSU these provisions will be applicable for all the payments made by BALMER LAWRIE on / after 1st October 2018. TDS shall be deducted @ 2% of taxable value excluding GST. TDS deducted from your payments will be deposited with GST authorities by 10th of the following month and TDS certificates will be issued subsequently.**

7. Tenderer should quote only rate as per UOM (unit of measurement) basis mentioned in the On-Line Price Format and any other basis is not acceptable. Offer from Bidder should contain all the elements such as Basic rates, GST, Freight etc. separately.

**8. Award of Contract**

**BL shall place the Purchase order on the Composite Lowest Quoted Bidder for the tender and as such it would be in the interest of the bidders to quote their most competitive price.**

**Negotiations, if held will be only with the lowest bidder.**

**9. DELIVERY INSTALLATION & COMMISSIONING OF THE SYSTEM**

i) To our plant at Silvassa. The supplier shall complete the supplies / installation & Commissioning within **12 weeks** from the date of the purchase order.

ii) **Packing & Marking**

The item should be so packed to withstand the hazards normally encountered with the means of transport, including loading and unloading operation. The material shall be suitably protected from water ingress especially during Monsoon. The successful bidder shall be held liable for all damages to the item due to defective or insufficient packing.

**10. Transit Risk Insurance**

Transit Risk Insurance shall be covered by the bidder from the successful bidder's stock point to BL's plants.

Any failure by the bidder to do so shall place the consignment at the bidder's risk.

**11. Guarantee/ Warranty**

The manufacturer / supplier / bidder shall provide in writing necessary guarantee /warranty that the item(s) manufactured and supplied to BL shall be new and free from defects in material, workmanship and design & construction and it will perform in accordance to the specification for a period of 12 months from the date of commissioning of the equipment or 18 months from the date of supply whichever is earlier. In the event of any deviation / nonperformance as per technical specification, the successful bidder will ensure repairing of the equipment / defective part(s) failing which will give free replacement with new machines or defective parts or adjust the proportionate claim from the 10% retention money.

- a. All products will be on one year all comprehensive replacement warranty against all manufacturing defects. During the warranty period the Vendor shall have to provide quarterly preventive servicing.

- b. During Warranty period, all break-down calls should be attended to as under:

For any problem the service engineer shall rectify arising in functioning of the system, within 48 hrs from time of lodgement of complaint. The time which will be treated as the time of lodgement of the complaint will be the 1st Call on mobile or the time of 1st e-mail send to the service centre in this regard.

- 11.1. In case of unsatisfactory performance of the successful bidder either in relation to quality of material or adherence of specified delivery schedule, Company reserves its right to cancel part or whole of the order and forfeit such amounts, as the Company may deem reasonable due to the loss of goodwill, business and goods due to such unsatisfactory performance, from the security deposit (s) deposited by the successful bidder.
- 11.2. The vendor has to submit a certificate from the manufacturers along with technical specifications that they are the authorized agents for the sale and service of their product and manufacturer undertakes to support the after sales service of the product.

Tenderer will have to submit a certificate from the manufacturer that the spare parts for the supplied product will be available for after sales service.



**C. GENERAL TERMS AND CONDITIONS**

**1. Introduction**

The bidder means the firm or company with whom the order is placed and shall be deemed to include the bidder, successors, representatives, heirs, executors and administrators.

Whenever there is a duplication of clause in the terms and conditions, the clause which is beneficial to BL will be considered applicable at the time of any dispute.

**2. Scope of Supply**

Scope of Supply for the tender shall be as mentioned in Annexure-I.

**3. Reference for Documentation**

Purchase Order Number must appear on all correspondence, invoices, packing and on any documents or papers connected with the order.

**4. Confirmation of Order**

The successful bidder shall acknowledge the receipt of purchase order within 7 days following the mailing of this order in writing or through email and shall thereby confirm his acceptance of purchase order in entirety without exceptions

**5. Relaxation of Tender Terms & Conditions**

BL reserves the right to relax any of the tender conditions, if necessary, while finalizing the tender at its discretion.

**6. Rejection of Bids**

The bid of any bidder may be rejected if a conflict of interest between the bidder and BL is detected at any state. The decision of BL in this connection will be final.

**7. Delay in bidding**

Late tenders / delayed tenders will not be accepted by the ON LINE system.

**8. RISK PURCHASE**

In case delivery of material / execution of service is not effected as per given schedule , we reserve the right to cancel the order placed on you, and procure the material from any other source and the deduction on account of penalty as well as excess mount to be incurred by us, would be recovered from the party's due payments or security amount held with us.

**9. LIQUIDATED DAMAGES FOR DELAY IN DELIVERY / QUALITY PROBLEMS**

Successful bidder shall have to pay to the company by way of liquidated damages and not as penalty an amount equal to 1.0 % of the value of the materials so delayed for each week or part thereof such delay in delivery, subject to maximum of 5% of the total order value.

**10. Delay due to Force Majeure**

In the event of causes of force Majeure occurring within the agreed delivery terms, the delivery dates can be extended by the tenderer on receipt of application from the bidder within stipulated delivery period. Only those causes that depend on natural calamities, civil wars, national strikes and strikes /lockout at Bidder's works which have duration of more than seven consecutive calendar days are considered the causes of Force Majeure. The bidder must advise BL by a registered letter duly certified by local chamber of commerce or statutory authorities, the beginning and end of cause

of delay immediately, but in no case later than 10 days from the beginning and end of such cause of Force majeure condition as defined above.

BL reserves the right to ask Bidder to suspend despatches of goods/materials covered by this order for such period as they may think fit in the event of strikes, accidents or other causes beyond BL's control.

### **11. Sub-Contracts**

The successful bidder shall not assign the Contract in whole or part without obtaining the prior written consent of BL. The bidder shall, notwithstanding the consent and assignment, remain jointly and severally liable and responsible to BL together with the assignee, for and in respect of the due performance of the contract and the bidder's obligations there under.

### **12. Control Regulations**

Successful bidder warrants that all goods/materials covered by this order have been produced, sold, despatched, delivered and furnished in strict compliance with all applicable laws regulations, labour agreement, working conditions and technical codes and statutory requirements as applicable from time to time. All laws and regulations required to be incorporated in executing this tender are hereby deemed to be incorporated by this reference. Owner can disown any responsibility for any irregularity or contravention of any of the statutory regulations in the manufacture or supply of goods covered in the order. The Bidder shall ensure compliance with the above and shall indemnify tenderer against any actions, damages, costs and expenses of any failure to comply as aforesaid.

### **13. Vendors Obligation**

The vendor shall ensure that no damage is caused to BL's property/or any decorative structure/fittings while carrying out the work. It is obligatory on the part of the vendor to rectify/make good such damages at their own cost. The Tenderer shall remove all unused material, wash and clean the floors at their own cost and hand over the site in proper manner on completion of the work.

The work executed should be got approved by Balmer Lawrie & Co Ltd. and the Tenderer shall rectify any bad workmanship pointed out at any stage and remove from site all the rejected materials immediately.

### **14. Statutory Compliance**

The successful bidder should take coverage under the Workmen's Compensation Act for the workmen employed by them for the commissioning and erection of the items tendered in this tender. The successful bidder should also ensure that all compliances under PF/ESI/Contract Labor Registration etc. as applicable are complied with

### **15. Termination**

Without prejudice to BL's right to price adjustment by way of discount or any other right or remedy available to BL, BL may terminate the Contract of any part thereof by a written notice to the bidder if,

- i. The bidder fails to comply with any material term of the Contract.
- ii. The bidder informs BL of its inability to deliver the item or any part thereof within the stipulated Delivery Period or such inability otherwise becomes apparent.
- iii. The bidder fails to deliver the item within the stipulated Delivery Period and/or to replace any rejected or defective item promptly.
- iv. The bidder becomes bankrupt or goes into liquidation.
- v. The bidder makes a general assignment for the benefit of creditors.
- vi. A receiver is appointed for any substantial property owned by the bidder.
- vii. The bidder has misrepresented to BL, acting on which misrepresentation, BL has placed the Purchase Order on the bidder.

Upon receipt of said termination notice, the bidder shall immediately stop supply.

On termination of the contract, without prejudice to any other right or remedy available to BL under the contract, in the event of BL suffering any loss on account of delayed delivery or non-delivery, BL reserves the right to claim and recover damages from the bidder in respect thereof. The EMD / Security Deposit will be forfeited

#### **16. Arbitration**

Any dispute or difference arising under this Contract shall be referred under jurisdiction of **Mumbai** to a sole arbitrator to be appointed by the Chairman & Managing Director, Balmer Lawrie & Co. Limited and the provisions of Arbitration Act, 1996 including any statutory modifications or enactment thereof shall apply to the Arbitration proceedings. The fees of the arbitrator, if any, shall be shared equally by both the parties. The award shall be a speaking award stating reason therefor and is final & binding on the parties. The proceeding shall be conducted in English language and courts at **Mumbai** will have exclusive jurisdiction to settle any dispute arising out of this contract.

***“In event of any dispute or difference relating to the interpretation and application of the provision of commercial contract(s) between Central Public Sector Enterprises (CPSEs) / Port Trusts inter se and also between CPSEs and Government Departments/Organizations (excluding disputes concerning Railways, Income Tax, Customs & Excise Departments), such disputes or difference shall be taken up by either party for resolution through AMRCD as mentioned in DPE OM no 4(1)/2013-DPE(GM)/FTS-1835 dated 22.05.2018”***

#### **17.HSE REQUIREMENTS BY CONTRACTORS**

##### **Housekeeping**

Contractors shall ensure that their work area is kept clean tidy and free from debris. The work areas must be cleaned on a daily basis. Any disposal of waste shall be done by the Contractor.

All equipment, materials and vehicles shall be stored in an orderly manner. Access to emergency equipment, exits, telephones, safety showers, eye washes, fire extinguishers, pull boxes, fire hoses, etc. shall not be blocked or disturbed.

##### **Confined Space**

Before commencing Work in a confined space the Contractor must obtain from Owner a Permit to Work, the Permit to Work will define the requirements to be followed.

As minimum Contractors must ensure the following:

- a) Confined spaces are kept identified and marked by a sign near the entrance(s).
- b) Adequate ventilation is provided
- c) Adequate emergency provisions are in place
- d) Appropriate air monitoring is performed to ensure oxygen is above 20%.
- e) Persons are provided with Confined Space training.
- f) All necessary equipment and support personnel required to enter a Confined Space is provided.

##### **Tools, Equipment and Machinery**

The Contractor must ensure that all tools & equipment provided for use during the Work is:

- a) suitable for its intended use;
- b) safe for use, maintained in a safe condition and where necessary inspected to ensure this remains the case (any inspection must be carried out by a competent person and records shall be available);
- c) Used only by people who have received adequate information, instruction and training to use the tool or equipment.
- d) Provided with Earth leakage circuit breaker (ELCBs) at all times when using electric power cords. Use of electrical tape for temporary repairs is prohibited.

##### **Working at Height**

Any Work undertaken where there is a risk of fall and injury is considered to be working at height.

**SBU: Industrial Packaging**

For any Contractor Personnel working at height, Contractors shall provide fall prevention whenever possible and fall protection only when fall prevention is not practicable. Before commencing Work in a height the Contractor must obtain from Owner a Permit to Work, the Permit to Work will define the requirements to be followed. Supervisor must be present at all point of time, to ensure no deviation occur during the course of work.

**Fall Prevention System**

Fall prevention systems (e.g. fixed guardrails, scaffolds, elevated work platforms) must provide protection for areas with open sides, including exposed floor openings.

**Fall Protection Systems**

Where fall protection systems are used then the Contractor must ensure the following is applied:

- i. Only approved full body harness and two shock-absorbing lanyards are used,
- ii. Prior establishment of a rescue plan for the immediate rescue of an employee in the event they experience a fall while using the system,
- iii. Anchorage points must be at waist level or higher; and capable of supporting at least the attached weight,
- iv. Lifeline systems must be approved by Owner before use.
- v. Use of ISI marked industrial helmet at all point of time.

**Scaffolding**

All scaffolds shall subject to a documented inspection by a competent person and clearly marked prior to use. The footings or anchorage for scaffolds shall be sound, rigid and capable of carrying the maximum intended load without settling or displacement. All scaffolding materials should be of MS tubular type.

Guardrails and toe-boards shall be installed on all open sides and ends of scaffold platforms. Scaffolds shall be provided with an access ladder or equivalent safe access. Contractor Personnel shall not climb or work from scaffold handrails, mid-rails or brace members.

**Stairways and Ladders**

Ladders should only be used for light duty, short-term work or access in line with the below and the Site Requirements.

- i) Fabricated ladders are prohibited.
- ii) Ladders will be secured to keep them from shifting, slipping, being knocked or blown over.
- iii) Ladders will never be tied to facility services piping, conduits, or ventilation ducting.
- iv) Ladders will be lowered and securely stored at the end of each workday.
  - a) Ladders shall be maintained free of oil, grease and other slipping hazards
  - b) Ladders will be visually inspected by a competent person and approved for use before being put into service. Each user shall inspect ladders visually before using.
  - c) Ladders with structural defects shall be tagged "Do Not Use," immediately taken out of service, and removed from the Site by the end of the day.

**Lifting Operations**

**Cranes and Hoisting Equipment**

Contractors shall operate and maintain cranes and hoisting equipment in accordance with manufacturer's specifications and legal requirements.

Only Contractor Personnel trained in the use of cranes and hoists are permitted to use them.

**Lifting Equipment and Accessories**

All lifting equipment / accessories e.g., slings, chains, webbing, chain blocks, winches, jacks etc shall be indicated with their safe working load have an identification number visible on the unit and be inspected and tested in accordance with legal requirements.

Damaged equipment / accessories and equipment shall be tagged "out of use" and immediately removed from Site.

**Lockout Tag out ("LOTO")**

Prior to performing work on machines or equipment, the Contractor shall ensure that it is familiar with LOTO and Permit to Work procedures and that all of its affected Contractor Personnel receive the necessary training.

### **Barricades**

Floor openings, stairwells, platforms and walkways, and trenching where a person can fall any distance shall be adequately barricaded and where necessary, well lit. Where there is a risk of injury from a fall then rigid barriers must be used.

Barricades must also be used to prevent personnel entering an area where risk of injury is high e.g., during overhead work activity or electrical testing etc. Such barricading must provide clear visual warning..

### **Compressed Gas Cylinders**

Gas cylinder shall be securely stored and transported, and identified and used in line with the local requirements. Hose lines shall be inspected and tested for leaks in line with local requirements. Flash Back arrestor to be used to prevent any explosion due to back fire.

### **Electrical Safety**

Prior to undertaking any work on live electrical equipment, the Contractor must obtain a Permit to Work from Owner. Where ever possible live work should be avoided. Any control measures highlighted shall be implemented prior to work commencing.

The below measures will be taken:

- a) Work practices must protect against direct or indirect body contact by means of tools or materials and be suitable for work conditions and the exposed voltage level.
- b) Energized panels will be closed after normal working hours and whenever they are unattended. Temporary wiring will be de-energized when not in use.
- c) Only qualified electrical Contractor Personnel may enter substations and/or transformer and only after being specifically authorized by Owner.

### **Hot Works**

A Permit to Work must be obtained from Owner prior to any hot works (welding, grinding, open flame work). Suitable fire extinguishing equipment shall be immediately available. Objects to be welded, cut or heated shall be moved to a designated safe location, or, if they cannot be readily moved, all movable fire hazards in the vicinity shall be taken to a safe place. Personnel working around or below the hot works shall be protected from falling or flying objects.

Prior to the use of temporary propane or resistance heating devices approval must be obtained from Owner.

### **Trenching, Excavating, Drilling and Concreting**

A Permit to Work must be obtained from Owner and all underground lines, equipment and electrical cables shall be identified and located prior to beginning the work. The Contractor shall assign a competent Contractor Personnel to all trenching and excavation work.

Safe means of access and egress shall be located in trench excavations. Daily inspections shall be conducted by a competent Contractor Personnel for evidence of a situation that could result in possible cave-ins, indications of failure of protective systems or other hazardous conditions.

Physical barriers shall be placed around or over trenches and excavations. Flashing light barriers shall be provided at night.

### **Environmental Requirements**

#### **Waste Management**

The Contractor is responsible to remove any waste generated by the work being done on the Site. The Contractor must dispose of the waste in line with the relevant local legislative requirements. The waste disposal route shall be documented and made available for Owner to review at any time and may be subject to Owner's prior approval.

Wastes (includes rinse from washing of equipment, PPE, tools, etc) are not to be poured into sinks, drains, toilets, or storm sewers, or onto the ground. Solid or liquid wastes that are hazardous or regulated in any way are not to be disposed of in general site waste receptacles.

### **Spills**

The Contractor is responsible for the provision of adequate spill kits/protection and the clean up and disposal costs arising from such spills.

**Emissions**

The Contractor shall identify and quantify any emission sources associated with the Works. The control measures associated with these emission shall be subject to the approval of Owner's Emissions include but are not limited to noise, dust, fumes, vapours.

<b>Company Seal</b>	<b>Signature</b>	
	<b>Name</b>	
	<b>Designation</b>	
	<b>Company</b>	
	<b>Date</b>	

**D - Annexure-I**

**SCOPE OF SUPPLY/WORK –**

“Supply of End Forming Die Set (2 Nos.)” at our Barrel Manufacturing Plant at Silvassa (UT of Dadra Nagar & Haveli), which consists of Design, manufacturing, supply & commissioning of complete Blanking & Forming Tool

**Quantity: Two no. [ Complete Set]**

**Location of Site:**

Balmer Lawrie & Co Ltd (1030)  
SBU – Industrial Packaging  
Survey no. 23/1/1, Khadoli  
Silvassa (UT of Dadra Nagar & Haveli) – 396230  
Ph - 0260-2649044, Fax – 0260-2699045

**General Specifications:**

The Blanking & Forming tool set should be heavy duty type and suited for our existing two power press i.e. both tool should have interchangeable option for using in both power presses. Tool should have provision of removable 2” & 3/4” bung hole punching and forming arrangement and ribbing arrangement. The tool should be able to produce both top and bottom lid by changing parts without removing die from the press. Tool should be designed for CRCA sheet metal of thickness 0.8mm to 1.5mm. Hardness of the sheet metal will be approx.40-60 HRB.

**Technical Specifications:**

- 1. Type:** Blanking and forming tool for CRCA steel thickness 0.80 mm to 1.5 mm. Blanking dia. of 642 mm. Tool has to be manufactured to produce top and bottom lid as per our drawing.
- 2.** Tool should have provision of interchangeable 2” & 3/4” punching and ribbing arrangement in addition with normal blanking and forming. There should also be an easy changeover mechanism for shifting to normal component to ribbed/punching component or vice versa.
- 3. Die Set:** Four pillar die set with ball cage bearings. Top & Bottom Plate/Bolster Plate Dimension: -  
Bottom Plate-Approx.950 X 950 X 60 mm  
Top Plate-Approx.950 X 950 X 60 mm  
Material-C45  
Top & bottom plate should be duly ground & parallel within 0.05mm.
- 4. Cutting & Forming Element:** Material AISI D2 or equivalent from reputed make like Ravne, Hitachi, Dew Boiler with duly Vacuum hardened (HRC 58-60) at all locations, cutting and forming diameters duly ground as per standard die tolerance. Die has to be provided with six segment shear arrangement at angle 2°. Material Mill test

certificate and certificate of hardness required along with the Blanking and forming tool. Forming die & Forming punch radius to be ground and lapped.

5. **Cushioning:** Die cushioning must be through Nitrogen cylinder of reputed make like Fibro, Misumi, Techapres, Danly etc.
6. All holding rings: Material MS duly ground to the specified tolerance. Drilling and tapping to be done at equi-distances.
7. Stripper: Material: C45. Both the surface to be machined smooth parallel with in 0.2mm
8. All cutting and forming ring to be ground.
9. No weld joint will be allowed.
10. All coil springs should be of very high quality of reputed make
11. Draw depth: Provision should be made for depth up to 25mm
12. Required Out Put: Able to match 30 strokes/min Power press Speed
13. The design has to be approved before commencement of manufacturing
14. The complete set of drawing has to be provided along with material.
15. Component: The die should produce components as per drawing

**NB:** A schematic drawing of the tool to be provided by the vendor along with tender document

Supplier must visit our workplace and inspect our existing Blanking and forming tool and Power Presses before quoting. All dimensions in drawings are indicative only.

Refer the drawing on next page –

1. Top End
2. Top End
3. Bottom End with Rib



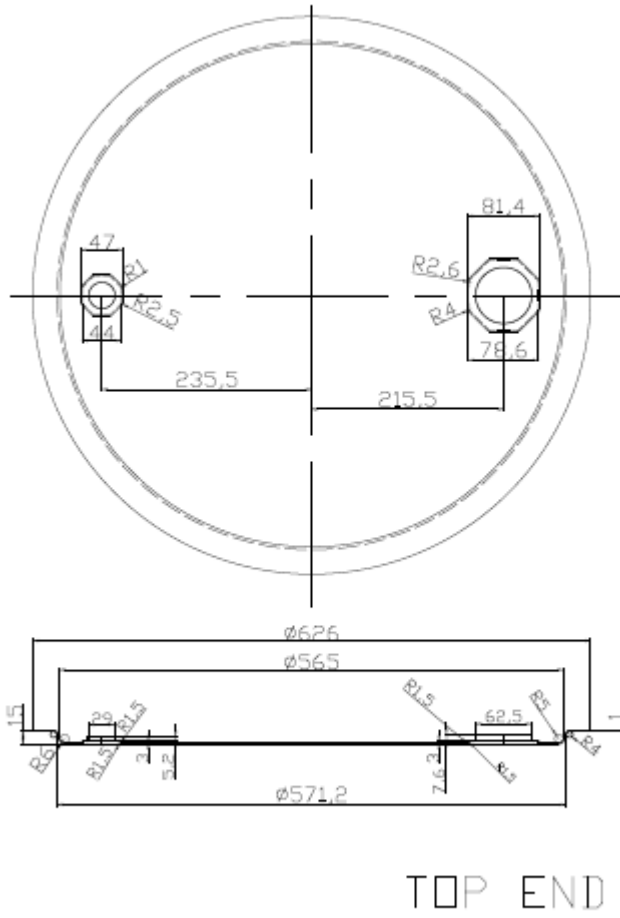

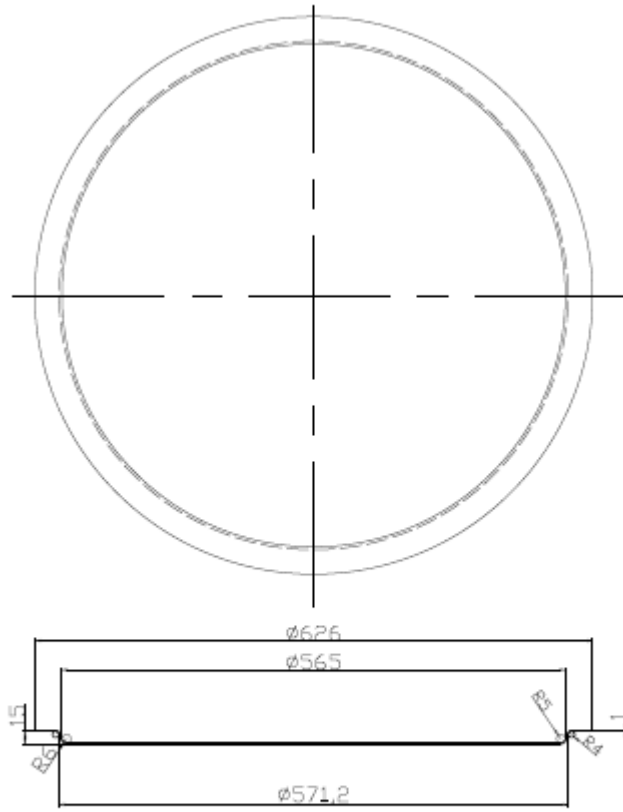

BOTTOM END

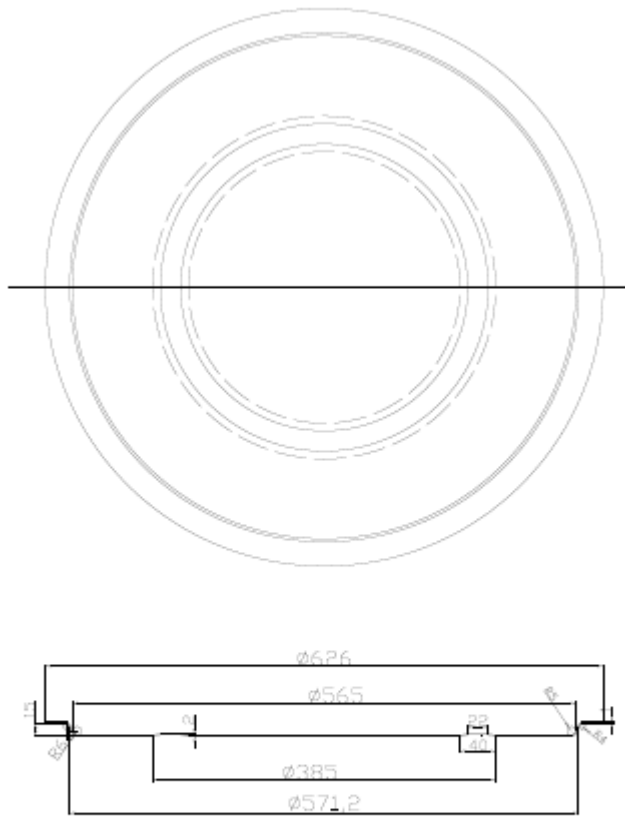

BOTTOM END  
WITH RIB

**E - ANNEXURE-II**

**PREQUALIFICATION CRITERIA**

<b>SR NO</b>	<b>Criteria</b>	<b>Documents need to submit</b>
1	The bidder shall have at least Three years of experience in supplying similar tools in past 3 years.	Certificate of Incorporation/Certificate of Registration/Trade License/Factory License/Shop and Establishment Certificate
2	The bidder is required to attach documentary evidences of successful supply & commissioning of Blanking & Forming tool set or similar type of tool set in last <b>7 years</b> and should meet either of the following criteria –  a) Three similar completed works costing not less than the amount equal to <b>12 Lakhs each</b> <b>or</b> b) Two similar completed works costing not less than the amount equal to <b>15 Lakhs each.</b> <b>or</b> c) One similar completed work costing not less than the amount equal to <b>24 Lakhs.</b>	Purchase Order copies and work completion certificate/Tax Invoices / CA Certified letter mentioning the number of orders completed with their respective value satisfying either of criteria
3	The bidders should have an average annual financial turnover during the last 3 years ( <b>2015-16,2016-17,2017-18</b> ), ending 31 <sup>st</sup> March of previous financial year, should be at least <b>Rs. 9 Lakhs</b>	Chartered Accountant Certified Profit & Loss & Balance Sheet copies.
4	Company's Permanent Account No. (PAN No) & GST No.	Copy of Certificate
5	Earnest money deposit <b>INR 15000.00</b>	EMD by way of Online mode as mentioned in <b>Annexure IX</b>
6	Regular submission of GST Return to the Authority along with proof of submission of return for FY 18-19 (GSTR-1 &GSTR-3B) *	Copy of (GSTR-1 &GSTR-3B)

**Note:**

- a. **Only those Vendors who meet the above Pre-qualification criteria will be qualified for opening of Price Bid subsequently.**
- b. **\*For bidder whose annual threshold limit is 40Lakhs is exempted for qualification in above clause in Sr.No 6**

F -ANNEXURE-III

(SAMPLE PRICE FORMAT. NOT TO BE FILLED IN. PRICE SHOULD BE QUOTED ON LINE ONLY)

S No.	Description of Item	Qty.	Rate Rs. /Set	Value (Rs.)	GST %	GST Value (Rs.)
1.	Supply of End Forming Die Set as per Annexure I	2 NOS				
2.	Packing Forwarding & Transportation	2 NOS				
3.	Installation & Commissioning Charges	2 NOS				
<b>TOTAL (1+2+3)</b>						

<b>Company Seal</b>	<b>Signature</b>	
	<b>Name</b>	
	<b>Designation</b>	
	<b>Company</b>	
	<b>Date</b>	

**G- ANNEXURE-IV**

**CONDITIONS FOR ONLINE BID SUBMISSION**

**1. Registration with eProcurement platform:**

For registration and online bid submission bidders may contact HELP DESK of M/s C1 India Pvt., Ltd.  
Contact Nos. and email IDs for C1 India helpdesk officers

1. Mr. Ujwala Shimpi, (022) 66865608 Email – [ujwala.shimpi@c1india.com](mailto:ujwala.shimpi@c1india.com)

(Mumbai / Monday - Friday)

2. Mr. Tirtha Das, Mob +91 -9163254290 Email - [tirtha.das@c1india.com](mailto:tirtha.das@c1india.com)

(Kolkata / Monday -Friday)

3. Mr.CH.Mani Sankar (Chennai), +91- 6374241783 Email– [chikkavarapu.manisankar@c1india.com](mailto:chikkavarapu.manisankar@c1india.com)

(Chennai / Monday -Saturday)

4. Helpdesk Support (Kolkata) Email [-blsupport@c1india.com](mailto:blsupport@c1india.com)

(Monday – Saturday) +91 -8017272644

**Escalation level** – Mr.Tuhin Ghosh, Mob. +91-8981165071 Email – [tuhin.ghosh@c1india.com](mailto:tuhin.ghosh@c1india.com)

**Requisites Before Login to System (Software requirements.)**

Minimum System Requirements:

- Pentium III or Later Processor
  
- Minimum of 128 MB of RAM
  
- Minimum 1 USB port (If Certificate is in USB Token)
  
- DSC Dongle driver should be installed before logging in
  
- Reliable Internet Connectivity
  
- Certificate with full chain
  
- Certificate should not be expired it should be valid certificate

**Operating System:**

- Windows 2000 Professional
  
- Windows XP

**Browser Version:**

- Internet Explorer Versions 6.0 SP2 and above

**Java Component:**

- Go to Control panel>Add/Remove Programs>
  
- Check whether Java Runtime Environment is installed on your machine or not.

**6. Procedure for Bid Submission**

The bidder shall submit his response through bid submission to the tender on e. Procurement platform at <https://balmerlawrie.eproc.in> by following the procedure given in the Catalogue.

**Digital Certificate authentication:**

The bidder shall authenticate the bid with his Digital Certificate (Class III) for submitting the bid electronically on e .Procurement platform and the bids not authenticated by digital certificate of the bidder will not be accepted on the e.Procurement platform.

All the bidders who do not have Digital Certificates need to obtain Digital Certificate. They may contact Help Desk of C1 India Pvt. Ltd.

**Bid Submission Acknowledgement:**

The user should complete all the processes and steps required for bid submission. The successful bid submission can be ascertained once acknowledgement is given by the system through bid submission number after completing all the processes and steps. Tender Inviting Authority and C1 India Pvt. Ltd. will not be responsible for incomplete bid submission by users. Users may also note that the incomplete bids will not be saved by the system and are not available for the Tender Inviting Authority for processing.

**4. Submission of Hard copies:**

**After submission of bid online, the bidders are requested to submit necessary documents if any which cannot be uploaded online to the Tender Inviting Authority before the due date at our Ballard Estate Office at 5, J.N.Heredia Marg, Ballard Estate, Mumbai-400 001. BL shall not take any responsibility for any delay or non-receipt of said documents. If any of the documents furnished by the bidder is found to be false / fabricated, the bidder is liable for black listing, forfeiture of the EMD, cancellation of work and criminal prosecution.**

**Disclaimer Clause**

The Company (Balmer Lawrie & Co. Ltd.) nor the service provider (C1 India Pvt. Ltd.) is responsible for any failure of submission of bids due to failure of internet or other connectivity problems or reasons thereof.

H - ANNEXURE- V

**(To be provided by successful bidder only)**  
**Proforma of the Bank Guarantee**  
**(Security Deposit)**

**Balmer Lawrie & Co. Ltd.**  
**5, J N Heredia Marg,**  
**Ballard Estate,**  
**Mumbai – 400 001.**

Dear Sir,

That Messrs. /Mr.\_\_\_\_\_ (set out full name and a Bidder and constitution of the Contractor) (hereinafter referred to as “the Contractor”) filed their / his / its quotation against your Tender being Tender No. ----- dated ----- (hereinafter referred as “the said Tender”) for Subject Job and in pursuance thereto an Order being No.\_\_\_\_\_ dated (hereinafter referred to as “the Order”) was issued by you to the Contractor.

The conditions of the said Tender, inter alia, require that the Contractor shall pay a sum of Rs. (Rupees only) as full security deposit (hereinafter referred to as “the security deposit”) in the form therein mentioned. The form of payment of security deposit includes a guarantee to be executed by a Scheduled Indian Bank.

The said Messrs. / Mr. \_\_\_\_\_ (set out full name of the Contractor) have / has approached us and at their / his / its request and in consideration of the premises. We \_\_\_\_\_ (set out full name of the Bank) having our office, inter alia at \_\_\_\_\_ (state the address of the Bank) has agreed to give such guarantee in the manner following:

1. We, \_\_\_\_\_ ( set out full name of the Bank ), hereby undertake and agree with you if default is made by Messrs. / Mr. \_\_\_\_\_ (set out full name of the Contractor ), in performing any of the terms and conditions of the Tender and / or Order or in payment of the security deposit or any other or in payment of money payable to you, We, \_\_\_\_\_ (set out full name of the Bank ) shall merely on demand from you without demur or protest shall pay you the said amount Rs. 000.00 (only ) or such portion thereof not exceeding the said sum as you may demand from time to time.
2. We, \_\_\_\_\_ ( set out full name of the Bank ), further agree with you that you shall have the fullest liberty to without our consent and without affecting in any manner our obligations hereunder to adopt any mode for realization of your dues from the Contractor and/or to vary any of the Terms and Conditions of your Contract with the said Messrs. / Mr. \_\_\_\_\_ ( set out full name of the contractor ) or to extend time of performance by Contractor from time to time or to postpone for any time or from time to time any of the powers exercisable by you against Contractor and to



forbear or enforce any of the terms and conditions relating to the Contract and We, \_\_\_\_\_ (set out full name of the Bank ) shall not be relieved from our liability by reason of any such variation, or any indulgence to be given by you to the Contractor or by any such matter or thing whatsoever which under the law relating to sureties would but for this provision have effect of so releasing us.

3. Your right to recover the said sum of Rs. 000.00 (Rupees only ) from us in the manner aforesaid will not be affected or suspended by reason of the fact that any dispute or disputes is / are pending before any Officer, tribunal, court or any other authority or authorities.
4. The guarantee herein contained shall not be determined or affect by liquidation or winding up, dissolution or change of constitution or insolvency of the said Messrs. / Mr. \_\_\_\_\_ (set out the full name of the Contractors), but shall in al respect, and for all purposes be binding and operative until payment of all the money due to you in respect of such liabilities is paid.
5. Our liability under this guarantee is restricted to Rs. 00.00 (Rupees only )
6. Our guarantee shall remain in force and effect until \_\_\_\_\_ (set out the date of Expiry) and unless a claim or demand in writing is made against us under this guarantee before the expiry of six months from the aforesaid date i.e. \_\_\_\_\_ (set out last date of Claim period), the said Guarantee all your rights under this guarantee shall be forfeited and We, \_\_\_\_\_ (set out full name of the Bank) shall be relieved and discharged from all liabilities there by.
7. We, \_\_\_\_\_ (set out full name of the Bank) undertake not to revoke this Guarantee during its currency except with your previous consent in writing.
8. We, \_\_\_\_\_ (set out full name of the Bank) have power to issue this Guarantee in your favor under our Memorandum and Articles of Association and the undersigned has full power to execute / sign this Guarantee under the Power of the Attorney dated the \_\_\_\_\_ day of \_\_\_\_\_ Two Thousand \_\_\_\_\_ granted by the Bank.

Yours faithfully,

Dated:

**GST Compliances**

**I- Annexure -VI**

- [1] Vendor to comply with all requirements under GST and provide their GST Registration details as per Annexure-VI attached
- [2] Vendor to issue a valid invoice with correct and complete disclosures as required under GST invoice rules and payments shall be processed only post receipt of correct invoice from the vendor
- [3] Vendor has to provide clear indication of place of supply [Invoicing location] related to place of supplies [BL location].
- [4] Vendors are required to raise invoice as per the GST tax structure.
- [5] Vendors to ensure that all invoices submitted are compliant with GST Laws. Any discrepancies in the Invoice which results in tax credit loss to Balmer Lawrie will be recovered from vendors.
- [6] In case of advance payment against goods/services, vendor to ensure payment of tax as per GST Laws.
- [7] Balmer Lawrie will keep a watch on compliance rating of their vendors as per the GST portal. If at any time such rating falls below prescribed criteria, Balmer Lawrie will have right to terminate the services without any prior notice to vendor.
- [8] **Vendor should compulsorily follow all the provisions of GST and in the event any default for fulfilling any provisions of the Act, BL would exercise the right for non-payment/withholding payment / black listing the vendor / debarring the vendor from participating in future tenders for a certain period [to be decided by BL].**

<b>Company Seal</b>	<b>Signature</b>	
	<b>Name</b>	
	<b>Designation</b>	
	<b>Company</b>	
	<b>Date</b>	

**J -ANNEXURE-VII**

**DETAILS OF VENDOR**

1	Name of the Vendor	
2	Address	
3	Postal Code	
4	State	
5	Country	
6	Telephone No.	
7	Mobile No.	
8	Fax No.	
9	Email ID	
10	Contact Person	
11	Bank Name	
12	Street	
13	City	
14	Branch Name	
15	IFSC Code	
16	MICR Code	
17	Account Number	
18	Minority Indicator	
19	GSTIN Registration Number	
20	HSN /SAC Code for Supply/Service	
21	GST rate (in %) applicable for Supply/Service to be provided.	
22	Composition Scheme Applicable	Yes / No
23	Proof of GSTIN Registration No. per state [From GSTN website]	
24	Vendor's GSP name [GST Suvidha Provider's]	
25	Exemption No.	
26	Exemption Percentage	
27	Exemption Reason	
28	Exempt From	
29	Exempt To	

K-ANNEXURE- VIII

**CPPP DECLARATION**

**BIDDER TO SUBMIT ON THEIR LETTER PAD**

(APPLICABLE TO ONLY MSE VENDORS FOR AVAILING BENEFITS AS PER PUBLIC PROCUREMENT POLICY FOR MSE's ORDER 2012.)

Dated .....

I/We, M/s .....,  
address....., hereby declare that I/We  
are registered as MSE supplier and have registered our Udyog Aadhar  
Memorandum (UAM) Number.....on Central Public Procurement  
Portal (CPPP).

Balmer Lawrie & Co. Ltd reserves the right to verify the authenticity of the  
above claim through CPPP.

I/We hereby also declare the following:-

- [1] I/We belong to SC/ST category – Yes / No [Kindly tick the appropriate category].
- [2] One of the partner / proprietors is a female – Yes / No [Kindly tick the appropriate category].

## **L-ANNEXURE - IX**

### **Terms and Conditions for making Online-Payments towards Earnest Money Deposit (EMD)**

The Terms and Conditions contained herein shall apply to any person (“User”) using the services of **Balmer Lawrie & Co. Ltd.**, hereinafter referred to as “Merchant”, for making Tender fee and Earnest Money Deposit (EMD) payments through an online Payment Gateway Service (“Service”) offered by ICICI Bank Ltd. in association with E Tendering Service provider and Payment Gateway Service provider through Balmer Lawrie e-procurement website i.e. <https://eproc.balmerlawrie.in> (“Website”). Each User is therefore deemed to have read and accepted these Terms and Conditions.

#### **A. Privacy Policy**

The Merchant respects and protects the privacy of the individuals that access the information and use the services provided through them. Individually identifiable information about the User is not willfully disclosed to any third party without first receiving the User's permission, as covered in this Privacy Policy.

This Privacy Policy describes Merchant's treatment of personally identifiable information that Merchant collects when the User is on the Merchant's website. The Merchant does not collect any unique information about the User (such as User's name, email address, age, gender etc.) except when you specifically and knowingly provide such information on the Website. Like any business interested in offering the highest quality of service to clients, Merchant may, from time to time, send email to the User and other communication to tell the User about the various services, features, functionality and content offered by Merchant's website or seek voluntary information from The User.

Please be aware, however, that Merchant will release specific personal information about the User if required to do so in the following circumstances:

- a) in order to comply with any valid legal process such as a search warrant, statute, or court order, or available at time of opening the tender
- b) if any of User's actions on our website violate the Terms of Service or any of our guidelines for specific services, or
- c) to protect or defend Merchant's legal rights or property, the Merchant's site, or the Users of the site or;
- d) to investigate, prevent, or take action regarding illegal activities, suspected fraud, situations involving potential threats to the security, integrity of Merchant's website/offerings.

#### **B. General Terms and Conditions For E-Payment**

Once a User has accepted these Terms and Conditions, he/ she may register on Merchant's website and avail the Services.

Merchant's rights, obligations, undertakings shall be subject to the laws in force in India, as well as any directives/ procedures of Government of India, and nothing contained in these Terms and Conditions shall be in derogation of Merchant's right to comply with any law enforcement agencies request or requirements relating to any User's use of the website or information provided to or gathered by Merchant with respect to such use. Each User accepts and agrees that the provision of details of his/ her use of the Website to regulators or police or to any other third party in order to resolve disputes or complaints which relate to the Website shall be at the absolute discretion of Merchant.

3. If any part of these Terms and Conditions are determined to be invalid or unenforceable pursuant to applicable law including, but not limited to, the warranty disclaimers and liability limitations set forth herein, then the invalid or unenforceable provision will be deemed superseded by a valid, enforceable provision that most closely matches the intent of the original provision and the remainder of these Terms and Conditions shall continue in effect.
4. These Terms and Conditions constitute the entire agreement between the User and Merchant. These Terms and Conditions supersede all prior or contemporaneous communications and proposals, whether electronic, oral, or written, between the User and Merchant. A printed version of these Terms and Conditions and of any notice given in electronic form shall be admissible in judicial or administrative proceedings based upon or relating to these Terms and Conditions to the same extent and subject to the same conditions

as other business documents and records originally generated and maintained in printed form.

5. The entries in the books of Merchant and/or the Payment Gateway Service Providers kept in the ordinary course of business of Merchant and/or the Payment Gateway Service Providers with regard to transactions covered under these Terms and Conditions and matters therein appearing shall be binding on the User and shall be conclusive proof of the genuineness and accuracy of the transaction.
6. **Refund For Charge Back Transaction:** In the event there is any claim for/ of charge back by the User for any reason whatsoever, such User shall immediately approach Merchant with his/ her claim details and claim refund from Merchant alone. Such refund (if any) shall be effected only by Merchant via payment gateway or by means of a demand draft or such other means as Merchant deems appropriate. No claims for refund/ charge back shall be made by any User to the Payment Gateway Service Provider(s) and in the event such claim is made it shall not be entertained.
7. In these Terms and Conditions, the term “**Charge Back**” shall mean, approved and settled credit card or net banking purchase transaction(s) which are at any time refused, debited or charged back to merchant account (and shall also include similar debits to Payment Gateway Service Provider's accounts, if any) by the acquiring bank or credit card company for any reason whatsoever, together with the bank fees, penalties and other charges incidental thereto.
8. Refund for fraudulent/duplicate transaction(s): The User shall directly contact Merchant for any fraudulent transaction(s) on account of misuse of Card/ Bank details by a fraudulent individual/party and such issues shall be suitably addressed by Merchant alone in line with their policies and rules.
9. Server Slow Down/Session Timeout: In case the Website or Payment Gateway Service Provider's webpage, that is linked to the Website, is experiencing any server related issues like 'slow down' or 'failure' or 'session timeout', the User shall, before initiating the second payment, check whether his/her Bank Account has been debited or not and accordingly resort to one of the following options:
  - i. In case the Bank Account appears to be debited, ensure that he/ she does not make the payment twice and immediately thereafter contact Merchant via e-mail or any other mode of contact as provided by Merchant to confirm payment.
  - ii. In case the Bank Account is not debited, the User may initiate a fresh transaction to make payment.  
However, the User agrees that under no circumstances the Payment Gateway Service Provider shall be held responsible for such fraudulent/duplicate transactions and hence no claims should be raised to Payment Gateway Service Provider No communication received by the Payment Gateway Service Provider(s) in this regard shall be entertained by the Payment Gateway Service Provider.

**C. Limitation of Liability**

1. Merchant has made this Service available to the User as a matter of convenience. Merchant expressly disclaims any claim or liability arising out of the provision of this Service. The User agrees and acknowledges that he/ she shall be solely responsible for his/ her conduct and that Merchant reserves the right to terminate the rights to use of the Service immediately without giving any prior notice thereof.
2. Merchant and/or the Payment Gateway Service Providers shall not be liable for any inaccuracy, error or delay in, or omission of (a) any data, information or message, or (b) the transmission or delivery of any such data, information or message; or (c) any loss or damage arising from or occasioned by any such inaccuracy, error, delay or omission, non-performance or interruption in any such data, information or message. Under no circumstances shall the Merchant and/or the Payment Gateway Service Providers, its employees, directors, and its third party agents involved in processing, delivering or

managing the Services, be liable for any direct, indirect, incidental, special or consequential damages, or any damages whatsoever, including punitive or exemplary arising out of or in any way connected with the provision of or any inadequacy or deficiency in the provision of the Services or resulting from unauthorized access or alteration of transmissions of data or arising from suspension or termination of the Services.

3. The Merchant and the Payment Gateway Service Provider(s) assume no liability whatsoever for any monetary or other damage suffered by the User on account of:
  - (I) the delay, failure, interruption, or corruption of any data or other information transmitted in connection with use of the Payment Gateway or Services in connection thereto; and/  
or
  - (ii) any interruption or errors in the operation of the Payment Gateway.
4. The User shall indemnify and hold harmless the Payment Gateway Service Provider(s) and Merchant and their respective officers, directors, agents, and employees, from any claim or demand, or actions arising out of or in connection with the utilization of the Services.

The User agrees that Merchant or any of its employees will not be held liable by the User for any loss or damages arising from your use of, or reliance upon the information contained on the Website, or any failure to comply with these Terms and Conditions where such failure is due to circumstance beyond Merchant's reasonable control.

**D. Miscellaneous Conditions:**

Any waiver of any rights available to Merchant under these Terms and Conditions shall not mean that those rights are automatically waived.

2. The User agrees, understands and confirms that his/ her personal data including without limitation details relating to debit card/ credit card transmitted over the Internet may be susceptible to misuse, hacking, theft and/ or fraud and that Merchant or the Payment Gateway Service Provider(s) have no control over such matters.
3. Although all reasonable care has been taken towards guarding against unauthorized use of any information transmitted by the User, Merchant does not represent or guarantee that the use of the Services provided by/ through it will not result in theft and/or unauthorized use of data over the Internet.
4. The Merchant, the Payment Gateway Service Provider(s) and its affiliates and associates shall not be liable, at any time, for any failure of performance, error, omission, interruption, deletion, defect, delay in operation or transmission, computer virus, communications line failure, theft or destruction or unauthorized access to, alteration of, or use of information contained on the Website.
5. The User may be required to create his/ her own User ID and Password in order to register and/ or use the Services provided by Merchant on the Website. By accepting these Terms and Conditions the User agrees that his/ her User ID and Password are very important pieces of information and it shall be the User's own responsibility to keep them secure and confidential. In furtherance hereof, the User agrees to;
  - i. Choose a new password, whenever required for security reasons.
  - ii. Keep his/ her User ID & Password strictly confidential.
  - iii. Be responsible for any transactions made by User under such User ID and Password.

The User is hereby informed that Merchant will never ask the User for the User's password in an unsolicited phone call or in an unsolicited email. The User is hereby required to sign out of his/ her Merchant account on the Website and close the web browser window when the transaction(s) have been completed. This is to ensure that others cannot access the User's personal information and correspondence when the User happens to share a computer with someone else or is using a computer in a public place like a library or Internet café.

**E. Debit/Credit Card, Bank Account Details**

1. The User agrees that the debit/credit card details provided by him/ her for use of the aforesaid Service(s) must be correct and accurate and that the User shall not use a debit/ credit card, that is not lawfully owned by him/ her or the use of which is not authorized by the lawful owner thereof. The User further agrees and undertakes to provide correct and valid debit/credit card details.
2. The User may make his/ her payment (Tender Fee/Earnest Money deposit) to Merchant by using a debit/credit card or through online banking account. The User warrants, agrees and confirms that when he/ she initiates a payment transaction and/or issues an online payment instruction and provides his/ her card / bank details:
  - i. The User is fully and lawfully entitled to use such credit / debit card, bank account for such transactions;
  - ii. The User is responsible to ensure that the card/ bank account details provided by him/ her are accurate;
  - iii. The User is authorizing debit of the nominated card/ bank account for the payment of Tender Fee and Earnest Money Deposit
  - iv. The User is responsible to ensure sufficient credit is available on the nominated card/ bank account at the time of making the payment to permit the payment of the dues payable or the bill(s) selected by the User inclusive of the applicable Fee.

**F. Personal Information**

1. The User agrees that, to the extent required or permitted by law, Merchant and/ or the Payment Gateway Service Provider(s) may also collect, use and disclose personal information in connection with security related or law enforcement investigations or in the course of cooperating with authorities or complying with legal requirements.
2. The User agrees that any communication sent by the User vide e-mail, shall imply release of information therein/ therewith to Merchant. The User agrees to be contacted via e-mail on such mails initiated by him/ her.
3. In addition to the information already in the possession of Merchant and/ or the Payment Gateway Service Provider(s), Merchant may have collected similar information from the User in the past. By entering the Website the User consents to the terms of Merchant's information privacy policy and to our continued use of previously collected information. By submitting the User's personal information to us, the User will be treated as having given his/her permission for the processing of the User's personal data as set out herein.
4. The User acknowledges and agrees that his/ her information will be managed in accordance with the laws for the time in force.

**Helpdesk**

For any payment related clarification/ assistance users may contact our helpdesk executives (Email- [sona.banerjee@ext.icicibank.com](mailto:sona.banerjee@ext.icicibank.com), Telephone- 033-40267513)

**G. Payment Gateway Disclaimer**

The Service is provided in order to facilitate payment of Tender Fees/Earnest Money Deposit online. The Merchant or the Payment Gateway Service Provider(s) do not make any representation of any kind, express or implied, as to the operation of the Payment Gateway other than what is specified in the Website for this purpose. By accepting/ agreeing to these Terms and Conditions, the User expressly agrees that his/ her use of the aforesaid online payment service is entirely at own risk and responsibility of the User.

**H. General Terms and Conditions -**



**SBU: Industrial Packaging**

1. It is advised that all bidders make payment via RTGS/NEFT/Debit Card /Credit Card at least one day in advance to the last day. In the event of bidder making payment on the last day and same is not available for bidder for validation on account of any reason whatsoever, Balmer Lawrie & Co. Ltd., its banker or e-Procurement service provider or payment gateway service provider would not be held responsible in any manner. In such cases bidder may not be able to submit the tender.
2. It is the bidder's responsibility to ensure that RTGS/NEFT RTGS/NEFT/Debit Card /Credit Card payments are made to the exact details as mentioned in the challan. In the event of any discrepancy, payment would not be considered and would not be available for validation of EMD payment.
3. Bidder is required to generate challan for every tender since details in the challan are unique to the tender and bidder combination. Bidder is not supposed to use challan generated in one tender for payment against another tender.
4. Under no circumstance, including whether the bidder has made duplicate/incorrect payments or correct payments not validated by the bidder for which tender validity has expired, Balmer Lawrie & Co. Ltd. or its Banker or its service providers are under no obligation to disclose the details of payment made by any bidder.
5. If you attempt to add beneficiary through internet banking then add the beneficiary account number printed in challan only. Please note that every challan have different beneficiary account number and hence do not attempt to use the same beneficiary account number for multiple cases.
6. No part payment should be made using account of same bank or other bank. Kindly ensure that full amount should be paid in one transaction. If multiple payments are made from one bank or multiple banks, then case will be disapproved and amount will be auto refunded.

**Annexure -X**

**M.LIST OF OFFICERS DESIGNATED FOR RELEASING PAYMENT**

Following are the details of designated officers responsible for processing of invoices/payment: -

<b>Sr.No.</b>	<b>Industrial Packaging -Location</b>	<b>Contact Person</b>	<b>Contact No.</b>	<b>email ID</b>
1	Silvassa	Mr. Prasoon Aggarwal	9555587372	<a href="mailto:aggarwal.p@balmerlawrie.com">aggarwal.p@balmerlawrie.com</a>
2	Kolkata	Mr. Shuvam Banerjee	9831737098	<a href="mailto:banerjee.shuvam@balmerlawrie.com">banerjee.shuvam@balmerlawrie.com</a>
3	Chennai	Mr. Manoj Karmakar	8124056521	<a href="mailto:karmakar.mk@balmerlawrie.com">karmakar.mk@balmerlawrie.com</a>
4	Chittoor	Mr. Pravin K Singh	9883325136	<a href="mailto:singh.pk@balmerlawrie.com">singh.pk@balmerlawrie.com</a>
5	Asaoti	Mr. D P Sharma	9717695849	<a href="mailto:sharma.dp@balmerlawrie.com">sharma.dp@balmerlawrie.com</a>
6	Taloja	Ms. Rekha	9867420162	<a href="mailto:rekha.rr@balmerlawrie.com">rekha.rr@balmerlawrie.com</a>
7	Vadodara	Mr. Vishal Gokharan	9819520229	<a href="mailto:vishal.g@balmerlawrie.com">vishal.g@balmerlawrie.com</a>

You are requested to contact the above officers for any queries pertaining to Invoices/payment.