

(Regd. Office: 21, N.S.Road, Kolkata-700001)

Tender Ref: BL/LC/MAN/CAP/LT/201718/0181

Dated: 22.11.2017

Due date: 05.12.2017

Sub: Inviting “e” bidding for Design, Supply, Erection, Commissioning and Testing of Wet Packed Bed FRP Scrubber and its accessories as per Specification at SBULC Manali – Req...

1. INTRODUCTION

Balmer Lawrie & Co Ltd. [herein after referred as BL] is a multiple product, multi location and multi technology conglomerate and manufacture of Leather Chemicals forms one of the core businesses of the company. The company invites ‘e’-bids for **Supply, Erection, Commissioning and Testing of Wet packed Bed FRP Scrubber** for their Chennai plant from approved and experienced Original Equipment Manufacturers/authorized dealers of OE manufacturers with sound infrastructural, technical and financial capabilities.

Offers from new vendors based on BL website enquiry, if any, will be considered for vendor development only, against this tender.

2. TENDER QUANTITY

Wet Packed Bed FRP Scrubber and its accessories - 1 No

3. ITEM TECHNICAL SPECIFICATIONS

The Scrubber shall be designed for Acidic vapour treatment application where the NaOH solution will be recirculating in the scrubber to absorb Acidic vapour on the surface of the packing column. The material of construction should be FRP + PP. The scrubber should be designed for continuous operation with 99.9 % efficiency.

S. no.	TENDER REQUIREMENT	
	DESCRIPTION	SPECIFICATION/REQUIREMENT
1	QTY	One set
2	CAPACITY	3000 CFM
3	VAPOUR / FUMES TO BE HANDLED	Chlorine, SO ₂ ,HCl, Monomer fumes and vapor
4	SCRUBBING LIQUID	Caustic Lye 16 % Concentrate
5	<u>SCRUBBER DIMENSIONS</u>	
a	SCRUBBER RE CIRCULATION TANK SIZE	2000x1300x700 (Approx.)
b	WALL THICKNESS	5 mm Thk PP + 5 mm Thk FRP (Bisphenol).Circumferential MS or FRP rings (100 X 8 mm) with frp lining to be provided on the shell for additional strength

Seal & Signature of the Tenderer:

c	VERTICAL PUMP MOUNTING FLANGES AND OTHER FLANGES	20 mm min
6	<u>SCRUBBER COLUMN</u>	
a	DIAMETER	800 mm (Approx.)
b	HEIGHT	5000 mm (Approx.)
c	AIR HANDLING VOLUME	3000 CFM
d	TYPE	Wet Type packed Bed
e	SYSTEM PRESSURE DROP	90 mm W.C
f	REMOVAL EFFICIENCY	Above 99%
g	<u>MOC</u>	
i	WALL THICKNESS	5 mm Thk PP + 5 mm Thk FRP (Bisphenol)
ii	FLANGE THICKNESS	20 mm
iii	PACKING MATERIAL	1" PP pall rings/tellerate rings Packings
h	COLUMN PACKING HEIGHT	2.1 Mtrs.
i	MIST ELEMINATOR	PP Mist eliminator of 150 mm Thickness
j	NOZZLES	Size -1"-8 No's. - SS nozzles.
k	SCRUBBER INLET DIA	350 mm
l	SCRUBBER OUTLET DIA	350 mm
m	CIRCULATING PIPES	HDPE (PN-10,PE-100)
7	<u>CIRCULATION PUMP</u>	
a	QUANTITY	2 Nos
b	SPECIFIC GRAVITY	1.1
c	CAPACITY	15 M3/Hr
d	TYPE	PP Vertical glandless pump
e	HEAD	15 m
f	NPSH (R) M	1 m
g	<u>MOC</u>	
i	IMPELLER,CASING,UPPER ROTOR CASING,EXPELLER	PP / UHMW – PE
ii	ADAPTOR	SS 410
iii	TIE RODS	SS 304
iv	MOUNTING FRAME	MS
v	MAKE	Process Pumps/SRB/Equivalent
h	<u>MOTOR</u>	
i	FLP MOTOR	FLP ,3 PHASE, 50HZ, INDUTION MOTOR ,415 V,2900 rpm
ii	MAKE	Kirloskar/BBL/CG

Seal & Signature of the Tenderer:

iii	HP& PRM	5 HP , 2900
iv	EFFICIENCY	IE2 /IE 3
8	BLOWER	
a	CAPACITY	3000 CFM / 150 mm W.C ,High Efficiency , Low noise Blower with inlet damper
b	DRIVE	Belt Drive with plumber block arrangements.
c	MOTOR CAPACITY	7.5 HP, Foot Mounted 415 V / 50 Hz / 3 PH / 1440 RPM TEFC / NFLP / 4 POLE SQUIRREL CAGE INDUCTION FLAME PROOF MOTOR(TEFC/FLP) - IE-2 / IE-3
d	MOTOR MAKE	Kirloskar/BBL/CG
9	DUCTING FROM COLUMN TO BLOWER	350 mm dia (3 mm frp + 2 mm PP) - with necessary required flanges(15 mm)
10	CHIMNEY	FRP+PP Chimney of 350 mm dia (3 mm frp(bisphenol) + 2 mm PP Thk) - with necessary required flanges(15 mm Thk)and Cowl. Length- 18 mts. (STRUCTURALS SUPPORT & LADDER WILL BE PROVIDED BY BL)
11	PIPING	HDPE (PN-10,PE-100)
12	DUCTING PIPE	350 mm dia (3 mm frp(bisphenol) + 2 mm PP Thk) - Length approximately - 65 mts. with necessary required flanges(15 mm Thk)and 100 mm dia (3 mm frp + 2 mm PP Thk) - Length approximately - 25mts.with necessary required flanges(15 mm Thk)
13	FLEXIBLE DUCTING HOSE	100 mm dia of chemical retardant flexible hose up to 25 m
14	PP DAMPER	Manual operated PP damper - 10 nos (350 mm & 100 mm)
16	CONTROL PANEL	Scrubber & blower
		Control panel to be provided with all safety accessories like single phase preventer and consist of incoming MCCB, , CONTACTORS, Control relays ,Overload Relays, Indication Lamps, Push button Switches etc.,
17	ACCESSORIES	
a	PACKING REMOVAL AND FILL UP ACCESS	To be provided
b	CLEAN OUT PORTS	To be provided
c	PACKING SUPPORT GRID	To be provided

Seal & Signature of the Tenderer:

d	Y STRAINER	To be provided
e	DRAIN WITH BALL VALVE	To be provided
f	WATER INLET VALVE	To be provided
18	<u>SAFTY ACCESSORIES</u>	To be provided
a	OVERFLOW PROVISION	To be provided
b	WATER LEVEL INDICATOR	To be provided
c	INSPECTION GLASS PORT FOR PACKING AREA	To be provided
19	BL SCOPE	SRUCTURALS SUPPORT & LADDER WILL BE PROVIDED FOR CHIMNEY PIPE

NOTE:

1. The Specification given above are indicative only. However, if vendor's equipment is spec is different, you can give the feedback for the required specification as given above separately. Deviations if any from our specifications can be mentioned as per format in the deviation sheet.

If required, technical clarifications / discussion will be done after the opening of the bid. The bids will be rejected in case if your equipment is not meeting the required operating efficiency / critical performance requirements / required output.

2. QAP and drawing of the scrubber to be approved by the BL.
3. Indicative sketch enclosed for reference.
4. Any bought out item to be mentioned separately and necessary certificate/drawing of the same to be submitted along with the offer.
5. Suppliers are requested to submit their offers preferably, after inspecting the site conditions
6. Kindly contact Mr. K Manivarman, 044-25946576 / 09445229921
E-mail: manivarman.k@balmerlawrie.com / raju.s@balmerlawrie.com for all technical related queries.

4. PREQUALIFICATION CRITERIA FOR PARTIES SUBMITTING OFFERS:

Firms submitting offers shall be well experienced in Engineering & Design. Moreover, they should be capable of executing the entire scope as detailed earlier. Also the firms submitting offer should meet the following pre-qualification criteria

- 4.1 Vendor shall have not less than five years of experience in supply of such FRP Scrubbers. List of scrubbers supplied year wise with capacity details, customer name & customer contact details from Apr 2012 to be submitted.

Seal & Signature of the Tenderer:

- 4.2** Vendor should have supplied minimum 3 nos of FRP scrubbers of any type within last five years of any capacity. Copies of POs / LOIs / any other documents supporting for such supplies from Apr 2012 to be submitted

Pre-qualification of the bidder shall not imply final acceptance of the tender. The bids may be rejected at any stage during the techno commercial; evaluation or during the price evaluation. The decision in regard to acceptance and / or rejection of any / all offers in part/full shall be at the sole discretion of BL, and decision in this regard shall be binding on the bidder. The vendor shall submit the relevant copies of the documents pertaining to each of the above qualification criteria and the all the copies have to be self-attested

5. EARNEST MONEY DEPOSIT

The bidder shall furnish an **EMD** for a sum of **Rs. 5,000 /-**(Rupees Five Thousand only) along with the bid by a/c payee pay order / demand draft / irrevocable bank guarantee (as per BL format enclosed as last page of the tender) in favour of Balmer Lawrie & Co Ltd payable at Chennai. DD should be valid for the period of at least 75 days from the due date of tender. The bank guarantee (BG) shall remain in force for at least 90 days from the due date of tender and shall be extendable on request made by BL prior to expiry of the BG.

a. OFFERS RECEIVED WITHOUT EMD WILL BE REJECTED

- b. For the successful bidder, the EMD will be refunded only after they submit the necessary security deposit. EMD will carry no interest.
- c. If the successful bidder is unable to accept or execute orders when placed upon him or withdraws / upwardly revises his quoted prices, within the validity period of his tender or after placement of the Order / Letter of Intent, successful Bidder fails to deliver the material as per the terms & condition of the Purchase Order or violates the tender conditions, his Earnest Money Deposit shall be forfeited.
- d. For the unsuccessful bidders, the EMD will be refunded only after the Purchase order has been released on the successful bidder.
- e. Linking of EMD amount with earlier transactions / adjustments with pending bills or any other amount payable by the company is not allowed.
- f. SSI UNITS WITH VALID REGISTRATION WITH NATIONAL SMALL INDUSTRIES CORPORATION LIMITED (MSME/NSIC), FOR THE ITEM/SERVICE TENDERED ARE EXEMPTED FROM PAYMENT OF EARNEST MONEY DEPOSIT.

NOTE: - Bidder having MSME/NSIC Registration needs to attach copy of valid Certificate applicable for the tendered product/service.

6. PRICE

- 6.1 The price to be submitted at our e-portal only, as per the indicative format below:

(Submission of offline price bid will disqualify the bidders' participation for the tender)

Seal & Signature of the Tenderer:

A. DESIGN AND SUPPLY OF WET PACKED BED FRP SCRUBBER AND ITS ACCESSORIES AS PER SPECIFICATION - 1No

Item	Particulars	Formula (if any)
1	Basic Price (Inclusive of P&F, Freight & Insurance) per unit	A
2a	CGST in %	B1=A* (Applicable CGST Rate in %)
2b	SGST in %	B2=A* (Applicable SGST Rate in %)
	OR	
3	IGST in %	B3=A* (Applicable IGST Rate in %)
4	Total Cost	C= SUM(A+(B1+B2) or B3)
5	Less: CGST	D= B1
6	Less: SGST	E= B2
7	Less: IGST	F= B3
8	Landed Cost	G= (C- (D+E) or F)
9	Unloading	By BL
10	HSN Code of the tendered item	To be provided by Vendor

B. ERECTION, COMMISSIONING AND TESTING OF FRP SCRUBBER- 1 No.

Item	Particulars	Formula (if any)
1	Basic Price for Installation/Erection, Commissioning and Testing per unit	A
2a	CGST in %	B1=A* (Applicable CGST Rate in %)
2b	SGST in %	B2=A* (Applicable SGST Rate in %)
	OR	
3	IGST in %	B3=A*(Applicable IGST rate in %)
4	Total Cost	C= SUM(A+(B1+B2) or B3)
5	Less: CGST	D= B1
6	Less: SGST	E= B2
7	Less: IGST	F= B3
8	Landed Cost	G= (C- (D+E) or F)
9	SAC Code (HSN Code) for Installation/Erection, Commissioning and Testing of the tendered item	To be provided by Vendor

Note:

Related Civil work, if any, for erection of the equipment/machinery will be carried out by BL. However, erection, commissioning and testing of the FRP scrubber is in Vendor's scope. Charges for erection and commissioning are to be given in the price bid as above. Any other extra charges are not payable by BL

Seal & Signature of the Tenderer:

The basic price should include the Freight, transit insurance, loading charges at supply premises, packing and forwarding. Price quoted should be on FOR Manali basis in **Rs. per unit.**

Vendor has to provide the applicable GST rate in % in the relevant fields as above during price bidding. If a vendor quotes with CGST & SGST, then they may ENTER "0" (Numerical Zero) in IGST field and similarly, If a vendor quotes with IGST, then they may ENTER "0" (Numerical Zero) in CGST & SGST fields.

Changes in statutory levies like GST and any taxes as applicable on the product shall be reimbursed at actuals based on documentary proof. Taxes and duties as applicable shall be clearly mentioned.

6.2 No Change in the accepted price structure on the basis of landed cost at our Manali works shall be permitted during the period of contract under any circumstances

7. SECURITY DEPOSIT

Successful tenderer shall be required to submit within 10 days of issue of LOI / PO, SD equivalent to 5% of the total order value rounded off to the nearest thousand rupees by a/c payee pay order / demand draft / irrevocable BG as per our format with a validity of further 3 months from expiry of the contract. The BG format will be issued to successful bidder. No interest will be payable on the SD held with us.

If SD is not received within 10 days from date of LOI/PO, the amount will be deducted from the vendor's bills, if any.

The Security Deposit paid by Pay Order/Demand Draft/Bank Transfer shall bear no interest and shall be refunded to successful bidder, only on successful delivery of the tendered item

All sums of compensation or other sums of money as determined, if any, payable by the bidder may be deducted from the Security Deposit.

The Security Deposit amount can be adjusted to the extent of EMD amount for the successful bidder.

Security deposit is liable to forfeiture in the event of:

- a. Not supplying the after Acceptance of Purchase Order.
- b. Successful Bidder fails to deliver the product as per the terms & condition of the Purchase Order.
- c. Successful Bidder violates the tender conditions.
- d. If the performance of the bidder is found to be unsatisfactory
- e. Any unilateral revision made by the successful bidder during the validity period of the contract.

8. PAYMENT TERMS

8.1 For Supply:

Our payment terms would be

-15% of basic as advance against submission of Advance Bank Guarantee valid for 6 months or valid for the delivery period whichever is later

Seal & Signature of the Tenderer:

-60% of basic with full duties and taxes: with 30 days credit from date of receipt and acceptance;

-15% of basic against erection and commissioning or within 30 days from the receipt of material, whichever is earlier.

-Balance 10% of basic against PBG valid for one year extended further by 3 months Or after one year of retention period.

8.2 For Erection, Commissioning and Testing:

100% upon satisfactory erection and commissioning, with 30 days credit from the submission of the bill. However bill must be submitted along with the copy of relevant proof of statutory payments, if any as required.

Note: In case of payment terms differing from above, suitable adjustments will be made in arriving at the landed cost while price comparison. However, partial advance payment if any prior to dispatch is payable only against Advance Bank Guarantee (taken from a nationalized bank) as per BL format.

Offers seeking payment before supply without Advance Bank Guarantee will be rejected.

Advance Bank Guarantee/Security Bank Guarantee/Performance Bank Guarantee format shall be given to successful tenderer and if the tenderer is submitting BG it shall be strictly as per our BG format only. In case of advance payment, ABG shall be submitted within 10 days from the date of LOI/PO.

8.3 Supply will be complete only if all relevant documents etc are submitted. Relevant Material test certificate for bought out items to be submitted along with dispatch.

8.4 Payment will be made only to the bidder or principal on whom the Purchase Order is placed. If offer states that payment is to be made to bidder's financier / creditor, the offer will stand rejected.

9. GUARANTEE

9.1 The party shall stand guarantee for material, workmanship and performance for a period of 12 months from the date of commissioning or 18 months from the date of supply, whichever is earlier.

9.2 The warranty/guarantee shall extent to the equipment and components manufactured by you or your vendor. In case of prolonged breakdown of equipment during warranty, the warranty period shall be extended proportionately.

9.3 During the above period, the party shall attend/repair/rectify /replace any defects whatsoever in material, workmanship and performance and make equipment ready for normal performance.

Seal & Signature of the Tenderer:

10. DELIVERY, ERECTION & COMMISSIONING

- 10.1** Delivery is expected **within 6-8 weeks** from the date of LOI/PO. However, earliest possible delivery period shall be mentioned clearly from the date of drawing approval. Vendor has to submit QAP and drawing of the scrubber for BL's approval within 7 days from the date of LOI/PO. BL will revert on approval with correction, if any within one week from receipt of QAP & drawing.

The delivery period mentioned above is inclusive of inspection & testing/transit time. No additional time shall be given separately for inspection/testing/transportation. Hence vendor has to plan and inform BL regarding the readiness of the equipment for inspection/testing with 1 week notice period, and BL shall confirm on inspection & testing within 2 days from the inspection notice given by the vendor.

Corrections/modifications as suggested by BL during inspection & testing to be implemented by the vendor within the mutually agreed period by BL & Vendor, based on the nature of corrections/modifications suggested.

Any delay in submission of Bank Guarantee, Drawings etc & delay due to inspection & testing/transportation will be counted into delivery time taken by vendor only

- 10.2** Erection and commissioning to be completed **within 30 days** from the date of site clearance

11. LD Clause:

The equipment shall be delivered and commissioned as per committed delivery schedule without fail. Any delay in delivery/commissioning as per agreed schedule will be liable for imposition of LD @0.5% of the total order value per week subject to a maximum of 5% on total basic value.

12. GENERAL TERMS AND CONDITIONS FORMING PART OF CONTRACT AND WORK ORDERS AWARDED FOR UNDERTAKING ERECTION & COMMISSIONING WORK FOR SRUBBER SYSTEM

- a) The successful tenderer shall be liable for due observance and implementation of statutory obligations. Before commencement of the work, you should take insurance coverage for your workmen for liabilities under Workmen Compensation Act. The proof of such coverage i.e. policy towards liabilities under Workmen Compensation Act should be shown to the Unit personnel Department before commencement of any work inside the factory premises.
- b) The successful tenderer shall keep the company indemnified from and against all claims, actions, demands, proceedings and liabilities whatsoever, including but not limited to Contract Labour Abolition and Regulation Act, 1970, the Workmen Compensation Act and the Industrial disputes Act and other applicable enactments.
- c) The successful tenderer must comply with all the provisions of EPF act and ESI act and the Rules there under.

Seal & Signature of the Tenderer:

- d) The successful tenderer shall maintain Register of workmen employed by you, muster, roll, wage register etc. and must comply with all the provisions of Contract Labour (Regulation & Abolition) Act, 1970.
- e) The successful tenderer should also obtain a license under provisions of Contract and Labour (Regulation and Abolition) Act 1970, if the same is applicable to you.
- f) The successful tenderer shall efficiently execute/ handle the work entrusted with you in accordance with the directions and specific instructions of the company and the work so entrusted shall not be regarded as having been correctly executed and efficiently handled until it is approved by the company
- g) In case the job entrusted / assigned to the successful tenderer is not satisfactorily executed or not in accordance with the specifications given by the company the tenderer shall be liable to compensate the same.
- h) In the event of strike / natural calamity due to which work has to be suspended, the Payment for such cases will not be made.
- i) In case of non-compliance of any of the above mentioned provisions, the company reserves the right:

to make such statutory payments that may be required in respect of your employees and then deduct the same from the bills submitted by the successful tenderer,

Or

to withhold the payment on the bills submitted by the tenderer till such time the successful tenderer comply with the statutory requirements.
- j) The successful tenderers employees should follow the rules and regulations of the company and observe the timings stipulated by the company.
- k) The successful tenderer shall not engage persons below 18 years of age for any work forming part of the contract.
- l) It shall be the successful tenderers responsibility to ensure that workers engaged by you use proper safety equipments while at work within the premises of the company.
- m) No Hot Work shall be carried out without obtaining the necessary Hot Work Permit, whenever required.
- n) The supplier will be liable to compensate for the damages to the company property, done by the personnel engaged by them.
- o) The supplier will be required to comply with the company's safety procedure & practices and any non-compliance will be considered as serious violation.

13. CONFLICT OF INTEREST

The bids of any tenderers may be rejected if a conflict of interest between the tenderer and the Company is detected at any stage

Seal & Signature of the Tenderer:

14. RISK PURCHASE

Without prejudice to other provisions in the tender, in the event of the vendor failing to supply within the stipulated delivery period, BL shall have the right and option to procure the products from alternate sources, at the risk and cost of the vendor, without further intimation. In case of rejection and with no request for re-test from vendor against the rejection or on confirmation of rejection after re-test, if dispatch of replacement material is not made within mutually agreed time period, BL shall have the right to procure the product from alternate sources, at the risk and cost of the vendor, without further intimation.

15. DELIVERY TO PLANT

Purchase Order under this tender will be placed for DELIVERED supplies. Transit Risk for the supplied material, Insurance coverage thereof will be borne by the supplier.

16. INSPECTION & TESTING

Inspection and testing of the equipment shall be conducted at the vendor's premises before delivery, in presence of BL representative. Performance test will be conducted at BL site after commissioning to achieve desired performance as per tender, in presence of BL representative.

Refer clause no. 10, Delivery.

Vendor has to provide 2 copies of operating and maintenance manual, with relevant documents, drawing, material test certificates, etc, if any related to the equipments along with soft copies of drawings/manuals.

Release note to be obtained from BL for dispatch clearance. Only after due clearance from BL, the equipment shall be dispatched from the vendor premises.

17. ARBITRATION

Any dispute or difference arising under this Contract shall be referred under jurisdiction of Chennai to a sole arbitrator to be appointed by the Chairman & Managing Director, Balmer Lawrie & Co. Limited and the provisions of Arbitration and Conciliation Act, 1996 including any statutory modifications or enactment thereof shall apply to the Arbitration proceedings. The fees of the arbitrator, if any, shall be shared equally by both the parties. The award shall be a speaking award stating reason therefore and is final and binding on the parties. The proceeding shall be conducted in English language and courts at Chennai will have exclusive jurisdiction to settle any dispute arising out of this contract.

18. GST TAX FORMALITES & COMPLIANCE WITH REGULATIONS

Vendor shall warrant that all goods covered by this agreement / contract are dispatched and delivered in strict compliance with all applicable laws, regulations, labour agreements, working conditions and technical codes and requirements as applicable from time to time. The vendor shall execute and deliver such documents as may be required to effect or to evidence such compliance.

Seal & Signature of the Tenderer:

The vendor shall issue the GST invoice so that equivalent amount may be availed as GST / applicable tax credit by BL. Vendor / vendor's nominated transporter shall ensure handing over of the GST paid invoice for availing concerned levy to the Company at the time of delivery of the consignment.

All laws and regulation required to be incorporated in this charter are hereby deemed to be incorporated by these references. BL and / or their authorized representatives disown any responsibility for any irregularity, contravention or infringement of any statutory regulations in the manufacture and / or supply of goods covered by this agreement / contract.

The processing of invoice should be as per the GST Act. Any penalties due to the non-adherence will be deducted from your invoice.

19. ANTI-PROFITEERING CLAUSE

GST Act anti-profiteering provisions mandates that any reduction in tax rates or benefits of inputs tax credits be passed on to the customer by way of commensurate reduction in prices. Vendors to take note of the same and pass such benefits to BL while quoting their price.

20. FORCE MAJEURE

Any delay in or failure of performance of either party hereto shall not constitute default hereunder or give rise to any claims for damage, if any, to the extent such delays / failure of performance is caused by occurrences such as Acts of God or an enemy, decrees of any Government or Governmental authority, acts of war, rebellion, sabotage or fires, floods, explosions, riots, or strikes. The vendor shall keep records of the circumstances referred to above and bring these to notice of the concerned Officer of the buyer in writing within 7 days of such occurrences.

The period of time, if any, lost on any of these counts shall not be counted for the contract period. The decision of buyer arrived at after consultation with vendor, shall be final and binding. Such period of time shall be extended by the buyer to enable the vendor to deliver the items within such extended period of time. As soon as the cause of Force Majeure been removed, the party whose liability to perform its obligation has been affected shall notify the other of such cessation and inform the other party the actual delay incurred in such affected activities. Any such event, whenever it occurs, provided that it prevents, affects or delays the party in performing contractual obligation, shall justify the claim of Force Majeure.

During the pendency of Force Majeure conditions, the Agreement and the obligations there under shall stand suspended provided the notice as required above is given in time. If such event continues beyond 14 days, the parties to this Agreement hereby agree to discuss and decide the course of action to be adopted in this regard including the possibility and manner of terminating the Agreement.

21. CONDITIONS / PROCEDURE FOR BID SUBMISSION

The bidder would be required to register on the e-procurement market place <https://balmerlawrie.eproc.in> and submit their price bids online. **No offline price bids shall be entertained by the Tender Inviting Authority.** The bidders shall submit their price bid displayed in e Procurement web site. The bidders shall submit/upload copies of all the relevant certificates, documents etc., in support of their eligibility criteria / technical bids to the Tender Inviting Authority before the due date for tender submission in the e-procurement portal. The bidder shall sign on the statements, documents, certificates, owning responsibility for their correctness/authenticity.

Seal & Signature of the Tenderer:

22. Registration with eProcurement platform

For registration and online price bid submission, bidders may contact HELP DESK of M/s C1 India Pvt., Ltd., or they can register themselves online by logging in to the website <https://balmerlawrie.eproc.in>. **Vendors need to get themselves registered online as above to participate in tender**

HELPDESK NOS ARE OPEN BETWEEN 1000 HRS to 1830 HRS IST		
(MONDAY TO FRIDAY (Exclusions: Balmer Lawrie HOLIDAYS))		
Please email your issues before your call helpdesk. This will help us serving you better.		
Contact Nos. and email IDs for Balmer Lawrie helpdesk officers		
Name	E-mail	Phone Numbers
1. Mr. Manisankar(Chennai)	chikkavarapu.manisankar@c1india.com	+91- 8939284159/044-25946556
2. Mr. Tuhin Ghosh	tuhin.ghosh@c1india.com	+91-8981165071
3. Mr. Tirtha Das	tirtha.das@c1india.com	+91-9163254290
4. Mr. Ravi Gaiwal	ravi.gaiwal@c1india.com	+91-022-66865633
5. Mr. Ujjal Mitra	ujjal.mitra@c1india.com	+91-8986678058

23. Digital Certificate authentication

The bidder shall authenticate the bid with his Digital Certificate before submitting the price bid electronically on e Procurement platform and the bids not authenticated by digital certificate of the bidder will not be accepted on the e Procurement platform.

All the bidders who do not have Digital Certificates with encryption need to obtain Digital Certificate with encryption to participate in e-tender. They may contact Help Desk of C1 India Pvt Ltd.



24. Corrigendum to tender

The bidder has to keep track of any changes by viewing the addendum / corrigendum's issued by the Tender Inviting Authority on time-to-time basis in our website www.balmerlawrie.com and our e-Procurement platform <https://balmerlawrie.eproc.in>. The Company inviting tender shall not be responsible for any claims / other issues arising out of this.

25. Bid Submission Acknowledgement

The user should complete all the processes and steps required for bid submission. The successful bid submission can be ascertained once acknowledgement is given by the system through bid submission number after completing all the processes and steps. Tender Inviting Authority and C1 India Pvt. Ltd. will not be responsible for incomplete bid submission by users. Users may also note that the incomplete bids will not be saved by the system and are not available for the Tender Inviting Authority for processing. Before uploading scanned documents, the bidders shall sign on all the statements, documents, certificates uploaded by him, owning responsibility for their correctness / authenticity.

26. SUBMISSION OF TENDER DOCUMENT [excluding price bid]

BL expects bidders' compliance of bid document without any deviation. Deviation if felt absolutely necessary in respect of terms & conditions / quality should be mentioned in the deviation sheet as per format of the tender documents and furnished along with the submission of offline tender documents. BL shall not take cognizance of any deviation stipulated elsewhere in the bid. **The deviations, if mentioned, are subject to approval by BL.**

Seal & Signature of the Tenderer:

Offline tender document shall comprise the following:

1. Copy of this tender document No. **BL/LC/MAN/CAP/LT/201718/0181** duly signed & stamped on all pages by the authorized signatory as a token of acceptance of tender terms & conditions.
2. **EMD for Rs. 5,000/- as Pay Order / DD / Irrevocable BG or NSIC/SSI/MSME certificate as applicable for exemption.**
3. Pre-qualification documents as sought in Clause 4.0
4. GA drawing of the scrubber to be submitted
5. Duly filled commercial terms as sought in **Annexure- 1**
6. Duly filled vendor details as sought in **Annexure- 2**
7. Deviation sheet as per format [nil statement to be attached even if there are no deviations].
8. The sealed envelope containing all the above documents super scribing **“Unpriced offer for – “Wet Packed Bed FRP Scrubber ”**, Ref: Tender No **BL/LC/MAN/CAP/LT/201718/0181 Due on 05.12.2017** shall be submitted as **hard copy** at the following address:

Senior Manager [SCM]
BALMER LAWRIE & CO. LTD.
SBU-Leather Chemicals
32, Sathangadu Village, Manali,
Chennai – 600068.

Phone : 044 – 25946543/00
Fax : 044 – 25941156
email:a.arun@balmerlawrie.com



27. SUBMISSION OF PRICE BID (ON-LINE ONLY)

27.1 Vendors to submit their price online only, as per the indicative format as per clause 6 as sought in our e-procurement portal.

27.2 SUBMISSION OF OFF- LINE PRICE BID WILL DISQUALIFY THE BIDDERS's PARTICIPATION IN THE TENDER

28. EVALUATIONS OF BIDS

The on-line closed price bids shall be used for grading the bidders. Evaluation of the price bids of **technically qualified bidders** will be done and overall lowest landed rate including erection and commissioning (net of GST, as applicable) shall be taken as L1 price and next lowest as L2 price and so on. Order will be awarded to L1 bidder including erection & commissioning.

Price bids of those tenderers who do not technically qualify for the tender, will not be considered for price evaluation and tender finalization

In case, bids are received from related Companies, only the lowest among such bids shall be considered for evaluation. The other bids of related Companies will stand rejected.

If required, during technical evaluation, the facilities of the manufacturer and their clients will be visited by BL for verification.

Seal & Signature of the Tenderer:

29. VALIDITY OF OFFER

Your offer should be valid for our acceptance up to **60 days** from the due date of this tender **(i.e. From 05.12.2017)**.

30. GENERAL

BL shall not take any responsibility for any delay or non-receipt of said documents. If any of the documents furnished by the bidder is found to be false / fabricated, the bidder is liable for black listing, forfeiture of the EMD, cancellation of work and criminal prosecution.

BL reserves the right to accept any tender in whole or split the order or reject any or all tenders without assigning any reason.

BL shall not be bound to accept the lowest tender and reserves the right to accept any or more tenders in part. Decision of BL in this context shall be final and shall be binding on the bidders.

Whenever there is a duplication of clause in the terms and conditions, the clause which is beneficial to the Company will be considered applicable at the time of any dispute

It may be noted that if any term is not mentioned in offer, it will be considered as per our tender only.

It shall be understood that every endeavor has been made to avoid error which may materially affect the basis of the tender and the successful bidder will take upon himself to provide for risk of any error which may subsequently be discovered and shall make no subsequent claim on account thereof.

31. DISCLAIMER CLAUSE

Neither the Company (Balmer Lawrie & Co. Ltd.) nor the service provider (C1 India Pvt. Ltd.) is responsible for any failure of submission of bids due to failure of internet or other connectivity problems or reasons thereof.

32. AWARD OF CONTRACT

The order will be awarded to the overall lowest quoted tenderer (including commissioning) based on the rate provided in the PRICE SCHEDULE in our e-procurement website.

If required, the Company would carry out negotiation with the tenderers and it would be in the interest of the tenderers to give their most competitive rates.

For Balmer Lawrie & Co Ltd

Senior Manager (SCM)

Encl: Annexure- 1 (2 pages) - Commercial Requirements

Annexure- 2 (1 page) - Vendor Details

Deviation Sheet Format- (1 page)

Indicative Sketch- (1 page)

BG Format for EMD (1- page)

Seal & Signature of the Tenderer:

Vendor is requested to confirm all the data provided in the table below:
Commercial:

SL No.	ITEM DESCRIPTION	BL REQUIREMENT	VENDORS OFFER
1	Validity	60 days from 05.12.2017	
2	Delivery	Delivery is expected within 6-8 weeks from the date of LOI/PO or earlier. However, earliest possible delivery period shall be mentioned clearly from the date of drawing approval. Vendor has to submit detailed drawing of the equipment for BL's approval within 7 days from the date of LOI/PO. BL will revert on approval with correction, if any within one week from receipt of drawing.	
3	Erection and commissioning	Erection and commissioning to be completed within 30 days from the date of site clearance	
4	Guarantee Period	12 months from the date of commissioning or 18 months from the date of supply, whichever is earlier.	
4	Payment Terms	<p>Supply: 15% of basic advance against submission of Advance Bank Guarantee valid for 6 months or valid for the delivery period whichever is later;</p> <p>60% of basic with full duties and taxes: with 30 days credit from date of receipt and acceptance;</p> <p>15% of basic against commissioning or within 30 days from the receipt of material whichever is earlier;</p> <p>Balance 10% of basic against PBG valid for one year extended further by 3 months Or after one year of retention period.</p> <p>Erection & Commissioning: 100% upon satisfactory erection and commissioning, with 30 days credit from the submission of the bill.</p>	

Seal & Signature of the Tenderer:

SL No.	ITEM DESCRIPTION	BL REQUIREMENT	VENDORS OFFER
5	Packing and Forwarding	To be included in the basic price	
6	Taxes & Duties		
a	GST (HSN /SAC code of the tendered item/service to be mentioned)	To be Specified by Vendor	
b	GST rate %	To be Specified by Vendor	
7	Transit Insurance	To be included in the basic price	
8	Transportation	To be included in the basic price	
9	Unloading	By BL	
10	Civil work for erection	By BL	
11	Erection, Commissioning and Testing	Vendor's Scope; Charges to be quoted in e-portal as per indicative format given in clause no. 6. OTHER THAN THE ABOVE NO ADDITIONAL CHARGES ARE PAYABLE FOR THE SAME	

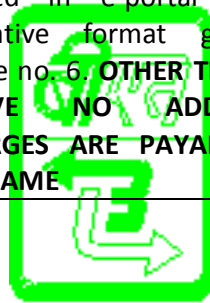

Seal & Signature of the Tenderer:

Vendor is requested to provide all the data in the table below, as applicable:

1.	Supplier Name	
2.	House No with address 1	
3.	Address 2	
4.	City	
5.	Postal code	
6.	State	
7.	Tel No	
8.	Mob No	
9.	Fax	
10.	Email	
11.	Industry Type*	Domestic / service vendor / MSME*/ SSI* / trader / others (specify it)
12.	If MSME registered, under category SC/ST?	
13.	Contact Person	
14.	Inco terms	
15.	Taxes applicable	
16.	PAN no*	
17.	State code (as per GST)	
18.	GSTIN Registration number*	
19.	Proof of GSTIN Registration number per state (From GSTN website)*	
20.	Vendor's GSP name (GST Suvidha Provider's)	

*** - relevant registration/certificate copies & statutory documents as per GST requirements shall be submitted.**

Seal & Signature of the Tenderer:

DEVIATION SHEET

Clause No. of the Tender	Tender Requirements	Deviation
		

Seal & Signature of the Tenderer:

- NOTE:
1. ALL DIMENSIONS ARE IN mm, UNLESS OTHERWISE SPECIFIED.
 2. MATERIAL PP WITH FRP.

INDICATIVE SKETCH FOR REFERENCE

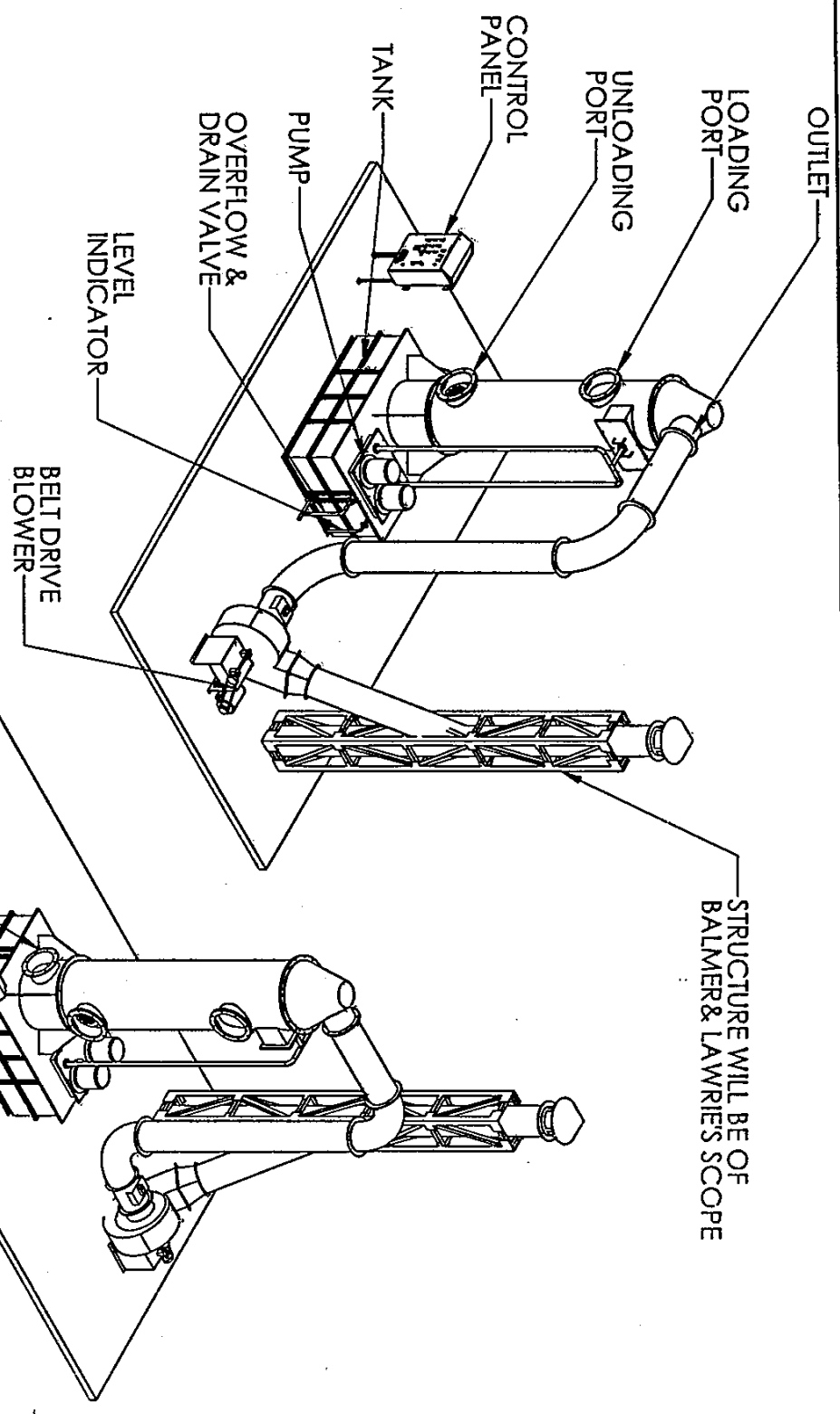
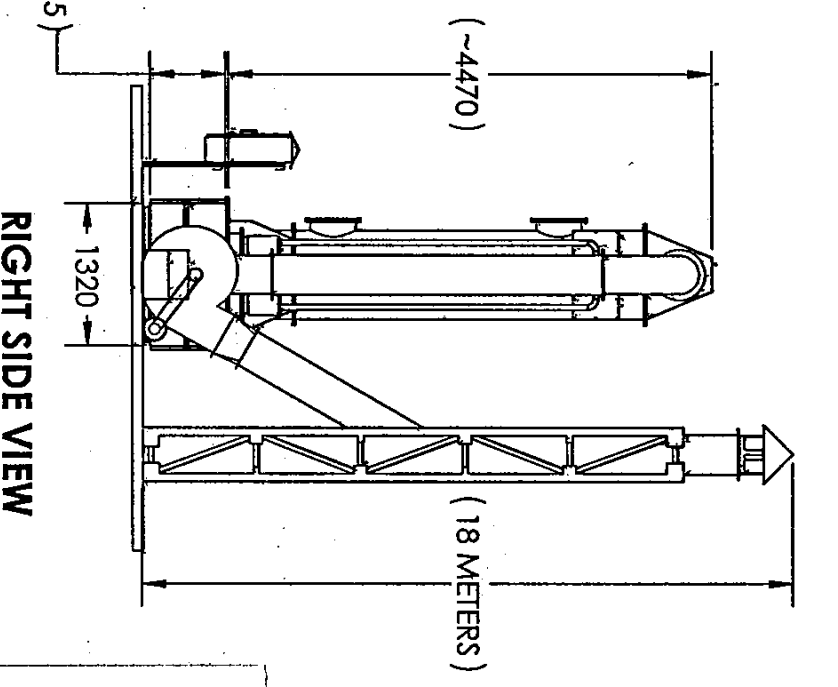
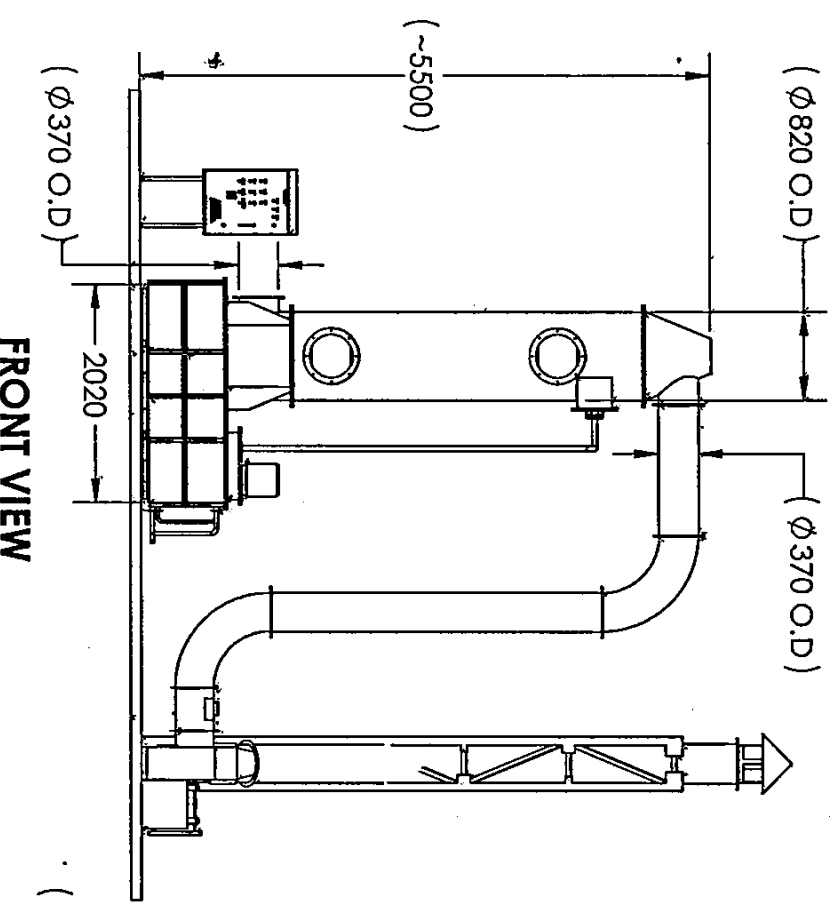
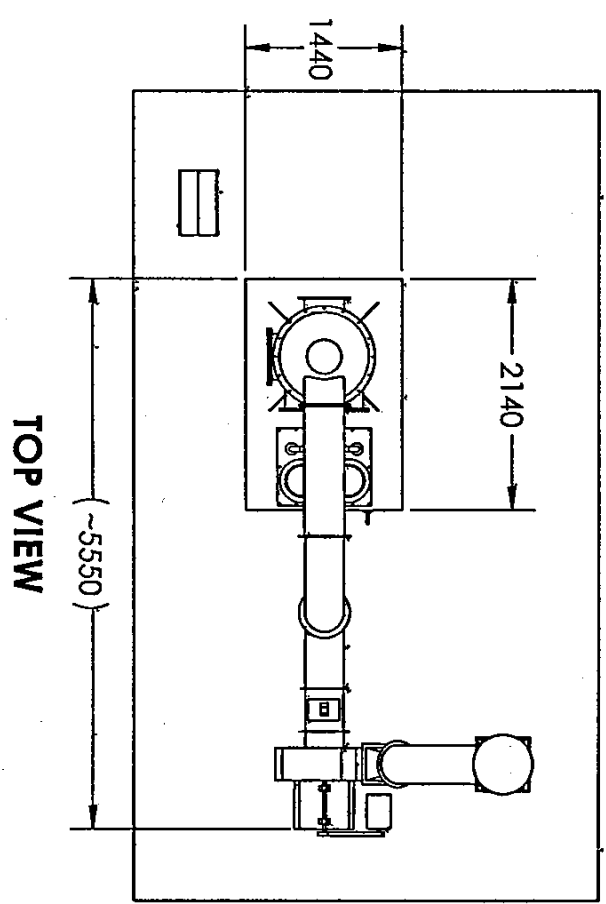

ISOMETRIC VIEWS

Proforma of the Guarantee
(Bid Bond / Earnest Money Deposit)

Lawrie & Co. Ltd.

Whereas (Name of the bidder) (hereinafter called "the Bidder") has submitted its bid for the (purpose) (hereinafter called "the Bid") against Tender reference No: dated of M/S BALMER LAWRIE & CO. LTD. (Address- Local).

The conditions of Tender provide that the Bidder shall pay a sum of Rs. (Rupees only) (hereinafter called "the said amount") as full Earnest Money Deposit in the forms (herein mentioned). The forms of payment of Earnest Money Deposit include guarantee to be executed by a Scheduled Bank.

The said (name and address of the Bidder) have approached us and at their request and in considerations of the premises we, (Name of the Bank) having our office at (address of the Bank) have agreed to give such guarantee as herein after mentioned.

Know All Men by these presents We, (name of the bank) of (address of the bank) having our office, inter alia, at (hereinafter called "the Bank") are bound unto BALMER LAWRIE & CO. LTD. (address) (hereinafter called "the Purchaser") in the sum of Rs (Rupees only) for which payment will truly be made to the Purchaser, the Bank binds itself, its successors and assigns by these presents this ... day of, 1999.

THE CONDITIONS of this obligation are:

1. If the Bidder withdraws its Bid during the period of bid validity specified by the Bidder on the bid form; or
2. If the Bidder, having been notified of the acceptance of its bid by the Purchaser during the period of bid validity:
 - a) fails or refuses to execute the Contract Form if required; or
 - b) fails or refuses to furnish the Performance Security, in accordance with the instructions to Bidders.

We undertake to pay the Purchaser up to the said amount upon receipt of its first written demand, without the Purchaser having to substantiate their demand, provided that in their demand the Purchaser shall mention that the amount claimed by them is due owing to the occurrence of one or both of the two conditions.

This guarantee will remain in force upto (date of expiry) including the days after the period of the bid validity, and any demand in respect thereof should reach the Bank not later than the above date.

Notwithstanding anything contained herein:

- i) Our liability under the Bank Guarantee shall not exceed Rs. (Rupees only.)
- ii) This Bank Guarantee shall be valid upto
- iii) We are liable to pay the guaranteed amount or any part thereof under this Bank Guarantee only if you serve upon us a written claim or demand on or before (last date of validity)

We, (name of the Bank) undertake not to revoke this guarantee during its currency except with your previous consent in writing.

We have power to issue this guarantee in your favour under our Memorandum and Articles of Association and the undersigned has full power to do and execute this Guarantee under the Power of Attorney dated day of , 1999 granted to him by the Bank.

Yours faithfully,

..... (Signature of Bank)