



बामर लॉरी एण्ड कं. लिमिटेड
(भारत सरकार का एक प्रतिष्ठान)

Balmer Lawrie & Co. Ltd.
(A Government of India Enterprise)

www.balmerlawrie.com

SBU – Industrial Packaging,
5, J. N. Heredia Marg, Ballard Estate,
Mumbai- 400001, India
Tel. No. 091 - 022 –66258209/66258188
Fax No. 091 - 022– 66258200

NOTICE INVITING TENDER

Tender No. 0100LC0948 dated 07.11.2017

Due date of Tender: 17.11.2017 at 15:00hrs.
Opening of e- Price Bid: 17.11.2017 at 15:30 hrs.

Two Bid “on line” offers against Limited e-tendering are invited for “Design, Fabrication, Installation & Commissioning of Motorized Vertical Coil lifter of 20MT SWL “ for our plant at Taloja- Maharashtra. The tender document can be downloaded from www.balmerlawrie.com website

Contact details

Balmer Lawrie & Co.Ltd.
SBU-Industrial Packaging,
G-15,16,17, MIDC Industrial Area, Taloja,
Dist : Raigad, Navi Mumbai – 410208.

Contact Persons:

1. A S Das-Landline-022 66258216
Mob. 7600067189
das.as@balmerlawrie.com

2. Mr.Kamlesh Lader-Landline-022 27412972
Mob.917718831931
lader.kk@balmerlawrie.com

Introduction:

Balmer Lawrie & Co. Ltd is a Mini-Ratna-I Public Sector Enterprise under the Ministry of Petroleum & Natural Gas, Government of India along with its six joint ventures in India & abroad. Today it is a much-respected transnational diversified conglomerate with presence in both manufacturing and service sectors. Balmer Lawrie is a market leader in Steel Barrels, Industrial Greases and Specialty Lubricants, Corporate Travel and Logistic Services. It also has significant presence in most other business. It operates, viz, Performance Chemical, Logistic Infrastructures etc. In Industrial Packaging, we are the leading manufacturer of MS Drums, holding the largest market share in India. The Company has a distributed manufacturing base with factories in Navi-Mumbai, Chennai, Chittoor, Silvassa, Asaoti and Kolkata. Our Plants are ISO Certified and conforms to Safety, Health and environment norms.

Instructions for bidders

1. On line Two bid Tenders are invited from the registered vendors only as per detailed specification contained in Annexure- I of this tender for our plant at Taloja,[Navi-Mumbai] .
2. **Please Refer to Annexure – I for detailed Technical Specifications and scope of work.**
3. The tender is invited **in Two-bid System.**
4. Important points to be noted

5.1 Due date for submission of bids 00.00.2017 at 15.00 hrs.

All Bids are to be completed in accordance with tender requirements within the duration as mentioned.

The bidders are requested to bid On line within the tender announcement date and tender closing date and time as mentioned in the tender document.

The term“**BL**” wherever mentioned in the tender document refers to “**Balmer Lawrie & Co. Ltd.**”

The successful bidder will be the Supplier.

This document is the Tender.

The Acceptance of the Order by the successful bidder will form the contract.

5. The **Site in connection with the supply, erection & commissioning of the required material** would be to our Barrel Manufacturing Plant at

Balmer Lawrie & Co. Ltd.,
SBU Industrial Packaging
G-15 16 17, GIDC Industrial Area, Taloja
Dist : Raigad, Maharashtra
PIN- 410208, Ph. No.- 022-27412660

6. Bid Security / Earnest Money Deposit(EMD)/ Bid Bond – **Rs.12500.00**

7. Bidders to note the Bid Rejection Criteria as detailed in Clause no.15.

8. Response from registered / Non registered Vendors will be accepted.

9. **MSEs HAVING VALID REGISTRATION AS PER PROVISION OF THE PUBLIC PROCUREMENT POLICY 2012 I.E. REGISTRATION WITH THE SPECIFIC DEPARTMENT [NSIC / MSME / DIC /] SPECIFIED BY MSE DIRECTORATE ARE EXEMPTED FROM PAYMENT OF EARNEST MONEY DEPOSIT. HOWEVER, MSEs REGISTERED WITH NSIC NEED TO HAVE REGISTRATION UNDER SINGLE POINT REGISTRATION SCHEME OF NSIC TO BE ELIGIBLE FOR SUCH EXEMPTION.**

10. **Bidder having NSIC/MSME/DIC Registration needs to attach complete set of copies of valid Certificate applicable for the tendered item/service.**

11. Corrigendum to tender:

The bidder has to keep track of any changes by viewing the addendum / Corrigendum's issued by the Tender Inviting Authority on time-to- time basis in the E-Procurement platform/ newspapers. The Company calling for tenders shall not be responsible for any claims/problems arising out of this.

12. Format of Tender

a. Tender documents consists of:

S.No.	Contents	Annexure
1	Scope Of Supply/work	I
2	Pre-qualification	II
3	Terms and Conditions	III
4	Price Bid	IV
5	Bank Guarantee	V
6	Conditions for Online Bid Submission	VI
7	GST Compliances & Details of Vendor	VII & VIII

b. The bidder is expected to examine the Tender documents, including all instructions, forms, General Terms & Conditions, Special Terms & Conditions, Technical Specifications and other documents and to fully familiarize itself with the requirements of the bidding documents. Failure to furnish all the information required by the Bidding Documents or the submission of a bid not substantially responsive to the Bidding Documents in every respect may result in the rejection of the Bid.

The copies of documentary proof must be submitted hard copies in separate envelope to Balmer Lawrie & Co. Ltd. 5, J. N. Heredia Marg, Ballard Estate, Mumbai – 400001, India on or before the due date and time.

13. Late Bids - No bidding will be accepted after the bid closing time & date.

14. Bid Validity

The offer shall remain valid for a period of three months from the date of opening of the Price Bid.

15. Bid Rejection Criteria

A bid may be rejected if

- i. The deviations from the terms mentioned in the document affects in any way the scope, quality and performance of the work.
- ii. Conflict of interest between the bidder and the Company is detected at any stage.

16. Clarifications

Clarifications that the Bidder needs to have on the tender specification can be sought from BL in writing by email within one week from the date of issue of this enquiry. All clarifications shall be by e-mail (Only email queries shall be replied)

17. Complete Scope of Work

The complete scope of work has been defined in Annexure- I of the tender document. Only those bidders who take responsibility and bid for the complete scope of work may be considered for further evaluation.

18. Tender Documents and Deviations

It is expected that bidders will submit bids based strictly on the terms and conditions and specifications contained in the bidding documents and will not stipulate any deviations. **Deviation from technical specifications, as given in the Tender Document-Annexure – I would invite immediate dis-qualification from further consideration of the bid.**

19. Preparation and submission of Tender Documents

The bidders are required to sign and stamp the tender document as a token of acceptance .

a. Price Bid (Annexure -IV is Price Bid)

The lowest bidder will be decided on the Nett delivered Price in Rupee, for the material/service mentioned in the scope of work. GST charges in % only converted in Rupee.

The Price bid should not contain any information other than the price. The price is to be mentioned in both Figures and words and where there is a difference between the two, rate given in words will be taken as authentic.

Price should be inclusive of charges for Packing & Forwarding / delivery / Installation & Commissioning.

Price bid should be filled as per the format provided (Annexure-IV) duly signed and stamped.

Annexure-I

Scope of Supply/Work :

Design ,Fabrication , Installation & Commissioning of Motorized Vertical Coil lifter of 20MT SWL, with Telescopic Arms Movement and Slewing Drive, for Automated Handling of CRCA steel coils along Horizontal axis.

Quantity : 01 Nos along with suitable stand with stair access .

Location of Site :

Balmer Lawrie & Co Ltd

Plot No : G-15,G-16 & G-17 ,M.I.D.C Industrial Area

Village : Padge , Taluka : Panvel ,

District : Raigad (Maharashtra)

General Description :

The vertical coil lifter will operate inside factory crane bay through 25 MT EOT crane and will be used for automated handling, lifting of CRCA coils.

To ensure automatic handling of coils, the equipment should be provided with two independent drives :

- a) Motorised Drive for rotation/slewing of the head along vertical axis , to position the coils precisely.
- b) Motorised Drive for sliding movement of telescopic arms.

The arms of the lifter should be designed for lifting and transporting coils having their axes in horizontal position.

To avoid any damage to steel coils during handling, the equipment should have the following features inbuilt in the design:

- a) Automatic back movement of arms to protect the coil edges from damage, after the coils are gripped and made ready for lifting.
- b) Provision of Full length Non- Metallic pads on all the surfaces which are in contact with the coil.
- c) Provision of Rubber or steel, toe / heal rollers in the lifting feet preferably.

Adequate number of limit switches, proximity sensors, should be provided to ensure operational safety during coil handling. Coil Alignment sensor, Coil loading sensor should be provided as a part of the safety feature.

Suitable Tower light / Indication lamps to aid the operator in aligning the lifter should be provided.

Suitable electrical &/ or, mechanical interlocking should be provided in the system to avoid any unintentional opening of the arms during lifting and transferring of coils.

Self- locking drive arrangement for arms movement will be preferred. The design of arms should ensure that it does not open out under impact or when inclined.

MOC:

The lifter should be fabricated out of Heavy duty High Tensile steel plates and should be designed for a Safe working load capacity of 20MT. Test certificate should be provided for steel used.

Geared brake motors : SEW /ABB/Siemens/ NORD/ROSSI/ EQUIVALENT.

Limit Switches : Siemens or Equivalent Reputed make

Contactors/ Relay : Siemens / Schneider or Equivalent Reputed make

LED signal/Indicating lamps : Siemens or Equivalent

Finish /Painting : Sand blasted ,
1st coat Red oxide/YELLOW OXIDE primer : 15-20 μ ,
Under Coat : 25- 30 μ , Top coat : 25 -30 μ
Colour : Golden Yellow with Black Zebra stripes

Note : The bidder should visit the factory site for designing the Suspension bail assembly.

Material to be handled: CRCA coil

CRCA Coil Dimensions:

Parameters	Minimum dimension	Maximum dimension	UOM
Width	900	1300	mm
Outside Diameter	1000	1700	mm
Inside Diameter	500	610	mm
Weight	7	15	MT
Temperature	Ambient	50° C	
Axis of coils to be handled	Horizontal		

Type of Crane	EOT
Safe Working Load of Crane	25MT
Maximum lift height of crane hook from Ground level	5.6 metres from Crane hook centre line to ground level.
Operation of EOT crane	Through Pendant and Remote
Installation	Indoor

Coil Lifter :

Safe Working Load	20MT
Type	Electro Mechanical type
Construction of body	Fabricated structure, Heavy duty High tensile steel.
Height of Equipment	Should be suitable to lift/ handle, 1700 mm OD coils to 2 high storage , with EOT crane having maximum clearance between Ground to Crane hook - 5.6 metres.

Dead weight of equipment	3.5 MT (maximum)
Geared motor for sliding movement of arms (i.e arms opening/closing movement)	Capacity- VTS, Duty-S4 (preferably) Brand - as per specs .
Geared motor for slewing motion of head along vertical axis	Capacity- VTS, Duty- S4 (preferably) Brand - as per specs.
Slewing /Rotation Angle	360 °
Limit switches, proximity sensors	To ensure operational safety. Brand – as per specs
Non Metallic pads	To protect coil surface . Suitable nos. to be provided on all the surfaces in contact with CRCA coil.
Finish	As per mentioned specs.
Operating Voltage	415 V ,3 phase ,50 Hz
Control Voltage	230V ,
Operation	<ol style="list-style-type: none"> 1. Through Pendant and remote control. 2. The supplier should provide suitable pendant to house, both the controls for coil lifter, & EOT crane at same location. 3. The supplier should provide suitable remote to house, both the controls for coil lifter, & EOT crane at same location. 4. Our EOT crane remote is made by HBC quadrix
Mounting of COIL LIFTER WITH THE CRANE HOOK	Note: The bidder may visit the factory site for designing the Suspension bail assembly or we can provide the required information by email documents. Existing Ramshorn hook need to be locked by the bidder in suitable position to mound the coil lifter

Parking Stand with stair access, suitable for the vertical coil lifter. - 1 no.

Test certificates to be provided by the successful vendor for the following :1. Safe Working Load 2.Ultrasonic testing of Steel plate

Operation and maintenance Manual

The bidder shall provide along with the equipment two sets (Hard and Soft copy) of operation and maintenance manual (in English) including manuals for mechanical / electrical function, assembly drawings, troubleshooting chart and preventive maintenance schedule of the machine parts, etc.

Warranty

The manufacturer / supplier / bidder shall warrant that the machine/equipment manufactured and supplied to BL shall be new and free from defects in material, workmanship and design & construction and it will perform in accordance to the specification for a period of 12 months from the date of commissioning of the machine or 18 months from the date of shipment whichever is earlier. In the event of any deviation, BL would seek free replacement with new machines or adjust the proportionate claim from the 10% retention money/Performance Guarantee.

Erection & Commissioning

The successful bidder shall depute its engineer(s) for erection / commissioning of the machine at our plant in Mumbai. The engineer(s) will train our technician(s) on operation and routine maintenance of the machine.

Crane Hook: Ramshorn Hook drawing attached.

Minimum clearance between hook and wire rope drum of the crane is 70mm

Maximum clearance between hook and wire rope drum of the crane is 140mm by rotating the hook 90 degrees

25MT RAMSHORN HOOK (DIN 15402)

WITH SAFTY LATCH

MATL - CLASS T₁ CrMo4-34

CrMo 5 (ALLOY STEEL)

QTY - 1 NO

WT / EACH - 55.0 KG.

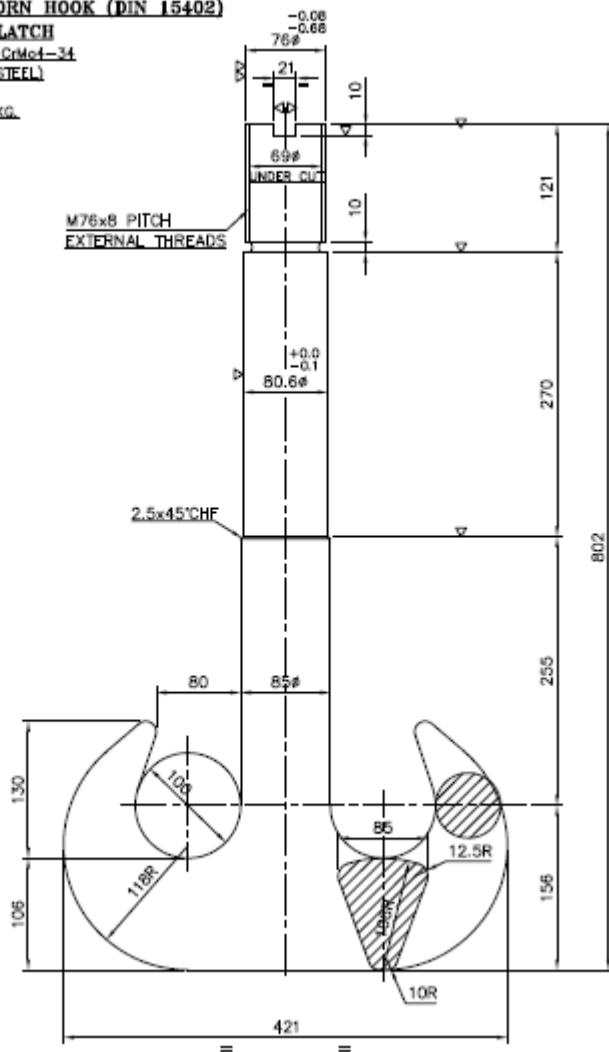

ANNEXURE-II

PRE QUALIFICATION CRITERIA:

1. Parties having experience (min. 5 years) in the field of design, manufacturing and supply of heavy duty motorized vertical coil lifters having similar technical features as per the specification given above, to manufacturing/steel industry will be qualified-
 - Self-certification required.
2. Turn Over for last three completed Financial Year
(Average Turn Over should not be less than Rs 5.0 Cr)
 - Provide suitable CA Certificate for last 3 years
3. No. of motorized Vertical coil lifters, similar technical features as per specs. given above and of capacity of minimum 10MT, manufactured and supplied in Last 3 Years: Minimum 1 no.
 - Provide detail list of customers along with contact person for reference
 - Provide Copy of POs
4. Value of largest single order executed in last 5 years : 2 POs not less than Rs.20 Lacks
 - Provide documentary proof
5. EMD D/D – Rs.12500.00 (NEFT is also acceptable)
6. GST Registration No.

Bidders not registered under GST are not eligible for participating in this tender. Vendors to mandatorily provide the Provisional GST Number as per Annexure- VII and also provide proof of such registration. Offers received from bidders who are not registered under GST, will not be considered for any evaluation against this tender.

ANNEXURE-III

TERMS & CONDITIONS

1. The tenderer means all parties/firms who respond against this tender notice and successful tenderer(s) mean party/parties, with whom the order is placed and shall be deemed to include the tenderer's successors, representatives, heirs, executors and administrators duly approved by the firm.

2. **Purpose of Contract:**

This contract is for Supply as per Annexure-I

The tenderer is expected to quote in accordance with the terms and conditions of the Company. Printed Standard conditions which may accompany the quotation of the tenderer will not be acceptable.

3. **Delivery period** – The successful tenderer should ensure the supply /erection & commissioning of Motorized Vertical Coil Lifter within 8-10 weeks from the date of the Purchase Order received from BL's Office.

4. **Tender Evaluation**

The tender would be finalized on the basis of technically accepted and Lowest Nett delivered price (NDP) Annexure -IV.

5. The company reserves the right to accept any tender or reject any or all tenders.

6. The bidders are specifically advised to note that the Company normally would not carry out any negotiations except with such parties who is / are the lowest bidders originally. As such, it would be in the interest of the bidders to quote lowest possible rates.

Negotiations, if held will be only with the lowest bidder.

7. **Validity of Quotation:** The quotation should be valid for the Company's acceptance for a **period of 60 days** (excluding the due date) from the date of opening of the tender.

8. **Sub-Contracting:** The successful bidder shall not be allowed to sub contract either wholly or any part of the order without Company's prior written consent.

9. **PAYMENT TERMS**

Our payment terms are as follows:

A] 30% of basic value will be released as an advance along with PO against equivalent Bank Guarantee from the successful bidder. BG will be released only after successful commissioning of Pallet Trucks.

B] 50% of basic value along with all taxes & duties will be released on receipt of the complete material.

C] 20% of the balance payment will be released only on successful commissioning of the Pallet Trucks at our factory and also on receipt of Performance Bank Guarantee (10% of the basic PO value for 12 months from the date of successful commissioning) from the bidder.

10. EMD :

Bidders will be required to pay of Rs.12500/- (Rupees Twelve thousand five hundred only) as an EMD amount in the form of D/D in favour of "Balmer Lawrie & Co. Ltd", payable at Mumbai and to be sent at our office address on or before the on line e-tender starts. A copy of the D/D is required to be attached at the time of up loading the tender. The Demand Draft/Pay order has to be made from a **Scheduled Indian Bank. Earnest Money Deposit can also be made directly to our Standard Chartered Bank (Account No. 222-0-526803-6, NEFT Code - IFSC "SCBL0036046) through electronic transfer and proof of transfer of funds deposited with us.** MSE vendors are exempted from submitting EMD amount . In that case, a copy of MSE current registration certificate (NSIC/SSI/DIC) is required to be submitted along with the hard copies.

11. SECURITY DEPOSIT(SD) & PERFORMANCE GUARANTEE (PG) :

Successful bidder will be required to provide SD for 10% of the Basic Value of the PO on receiving Purchase Order. The SD will be converted to Performance Guarantee and will be retained for 1 year from the date of commissioning . Equivalent Bank Guarantee will also be accepted.

12. RISK PURCHASE

In case delivery of the material is not effected as per given schedule from time to time, we reserve the right to cancel the order placed on you, and procure the material from any other source and the deduction on account of penalty as well as excess mount to be incurred by us, would be recovered from the party's security amount held with us.

13. INSPECTION :

M/s.Balmer Lawrie shall inspect the material after delivery at our factory in presence of Vendor's representative .

14. REJECTION.

If, as a result of inspection, examination or testing, M/s.Balmer Lawrie's Representative decides that any material is defective or otherwise not in accordance with the contract, M/s.Balmer Lawrie's Representative may reject such material and shall notify the Vendor promptly, stating his reasons. The Vendor shall then promptly remove the rejected item and replace with fresh material at his own cost.

15. WARRANTY PERIOD : Mentioned in Annexure- I

16. LIQUIDATE DAMAGE : In case, the successful bidder fails to supply the material within the stipulated period as per the Purchase Order, Liquidated Damages will be imposed @ 0.50% of the Total Purchase Order Value, per completed week up to a maximum of 5% of the total Purchase Order value.

17. Delay due to Force Majeure

In the event of causes of force Majeure occurring within the agreed delivery terms, the delivery dates can be extended by the tenderer on receipt of application from the bidder within stipulated delivery period. Only those causes that depend on natural calamities, civil wars, national strikes and strikes /lockout at Bidder's works which have duration of more than seven consecutive calendar days are considered the causes of Force Majeure. The bidder must advise BL by a registered letter duly certified by local chamber of commerce or statutory authorities, the beginning and end of cause of delay immediately, but in no case later than 10 days from the beginning and end of such cause of Force majeure condition as defined above.

BL reserves the right to ask Bidder to suspend despatches of goods/materials covered by this order for such period as they may think fit in the event of strikes, accidents or other causes beyond BL's control.

18 HSE REQUIREMENTS BY CONTRACTORS (To be followed by Contractors as per their area of concern)

Housekeeping

Contractors shall ensure that their work area is kept clean tidy and free from debris. The work areas must be cleaned on a daily basis. Any disposal of waste shall be done by the Contractor.

All equipment, materials and vehicles shall be stored in an orderly manner. Access to emergency equipment, exits, telephones, safety showers, eye washes, fire extinguishers, pull boxes, fire hoses, etc. shall not be blocked or disturbed.

Confined Space

Before commencing Work in a confined space the Contractor must obtain from Owner a Permit to Work, the Permit to Work will define the requirements to be followed.

As minimum Contractors must ensure the following:

- a) Confined spaces are kept identified and marked by a sign near the entrance(s).
- b) Adequate ventilation is provided
- c) Adequate emergency provisions are in place
- d) Appropriate air monitoring is performed to ensure oxygen is above 20%.
- e) Persons are provided with Confined Space training.
- f) All necessary equipment and support personnel required to enter a Confined Space is provided.

Tools, Equipment and Machinery

The Contractor must ensure that all tools & equipment provided for use during the Work is:

- a) suitable for its intended use;
- b) safe for use, maintained in a safe condition and where necessary inspected to ensure this remains the case (any inspection must be carried out by a competent person and records shall be available);
- c) Used only by people who have received adequate information, instruction and training to use the tool or equipment.
- d) Provided with Earth leakage circuit breaker (ELCBs) at all times when using electric power cords. Use of electrical tape for temporary repairs is prohibited.

Working at Height

Any Work undertaken where there is a risk of fall and injury is considered to be working at height.

For any Contractor Personnel working at height, Contractors shall provide fall prevention whenever possible and fall protection only when fall prevention is not practicable. Before commencing Work in a height the Contractor must obtain from Owner a Permit to Work, the Permit to Work will define the requirements to be followed. Supervisor must be present at all point of time, to ensure no deviation occur during the course of work.

Fall Prevention System

Fall prevention systems (e.g. fixed guardrails, scaffolds, elevated work platforms) must provide protection for areas with open sides, including exposed floor openings.

Fall Protection Systems

Where fall protection systems are used then the Contractor must ensure the following is applied:

- 1 Only approved full body harness and two shock-absorbing lanyards are used,
- 2 Prior establishment of a rescue plan for the immediate rescue of an employee in the event they experience a fall while using the system,
- 3 Anchorage points must be at waist level or higher; and capable of supporting at least the attached weight,
- 4 Lifeline systems must be approved by Owner before use.
- 5 Use of ISI marked industrial helmet at all point of time.

Scaffolding

All scaffolds shall subject to a documented inspection by a competent person and clearly marked prior to use. The footings or anchorage for scaffolds shall be sound, rigid and capable of carrying the maximum intended load without settling or displacement. All scaffolding materials should be of MS tubular type.

Guardrails and toe-boards shall be installed on all open sides and ends of scaffold platforms. Scaffolds shall be provided with an access ladder or equivalent safe access. Contractor Personnel shall not climb or work from scaffold handrails, mid-rails or brace members.

Stairways and Ladders

Ladders should only be used for light duty, short-term work or access in line with the below and the Site Requirements.

- i) Fabricated ladders are prohibited.
- ii) Ladders will be secured to keep them from shifting, slipping, being knocked or blown over.
- iii) Ladders will never be tied to facility services piping, conduits, or ventilation ducting.
- iv) Ladders will be lowered and securely stored at the end of each workday.
- v) Ladders shall be maintained free of oil, grease and other slipping hazards
- vi) Ladders will be visually inspected by a competent person and approved for use before being put into service. Each user shall inspect ladders visually before using.
- vii) Ladders with structural defects shall be tagged "Do Not Use," immediately taken out of service, and removed from the Site by the end of the day.

Lifting Operations

Cranes and Hoisting Equipment

Contractors shall operate and maintain cranes and hoisting equipment in accordance with manufacturer's specifications and legal requirements.

Only Contractor Personnel trained in the use of cranes and hoists are permitted to use them.

Lifting Equipment and Accessories

All lifting equipment / accessories e.g., slings, chains, webbing, chain blocks, winches, jacks etc shall be indicated with their safe working load have an identification number visible on the unit and be inspected and tested in accordance with legal requirements.

Damaged equipment / accessories and equipment shall be tagged "out of use" and immediately removed from Site.

Lockout Tag out ("LOTO")

Prior to performing work on machines or equipment, the Contractor shall ensure that it is familiar with LOTO and Permit to Work procedures and that all of its affected Contractor Personnel receive the necessary training.

Barricades

Floor openings, stairwells, platforms and walkways, and trenching where a person can fall any distance shall be adequately barricaded and where necessary, well lit. Where there is a risk of injury from a fall then rigid barriers must be used.

Barricades must also be used to prevent personnel entering an area where risk of injury is high e.g., during overhead work activity or electrical testing etc. Such barricading must provide clear visual warning..

Compressed Gas Cylinders

Gas cylinder shall be securely stored and transported, and identified and used in line with the local requirements. Hose lines shall be inspected and tested for leaks in line

with local requirements. Flash Back arrestor to be used to prevent any explosion due to back fire.

Electrical Safety

Prior to undertaking any work on live electrical equipment the Contractor must obtain a Permit to Work from Owner. Where ever possible live work should be avoided. Any control measures highlighted shall be implemented prior to work commencing.

The below measures will be taken:

- a) Work practices must protect against direct or indirect body contact by means of tools or materials and be suitable for work conditions and the exposed voltage level.
- b) Energized panels will be closed after normal working hours and whenever they are unattended. Temporary wiring will be de-energized when not in use.
- c) Only qualified electrical Contractor Personnel may enter substations and/or transformer and only after being specifically authorized by Owner.

Hot Works

A Permit to Work must be obtained from Owner prior to any hot works (welding, grinding, open flame work). Suitable fire extinguishing equipment shall be immediately available. Objects to be welded, cut or heated shall be moved to a designated safe location, or, if they cannot be readily moved, all movable fire hazards in the vicinity shall be taken to a safe place. Personnel working around or below the hot works shall be protected from falling or flying objects.

Prior to the use of temporary propane or resistance heating devices approval must be obtained from Owner.

Trenching, Excavating, Drilling and Concreting

A Permit to Work must be obtained from Owner and all underground lines, equipment and electrical cables shall be identified and located prior to beginning the work. The Contractor shall assign a competent Contractor Personnel to all trenching and excavation work.

Safe means of access and egress shall be located in trench excavations. Daily inspections shall be conducted by a competent Contractor Personnel for evidence of a situation that could result in possible cave-ins, indications of failure of protective systems or other hazardous conditions.

Physical barriers shall be placed around or over trenches and excavations. Flashing light barriers shall be provided at night.

Environmental Requirements

Waste Management

The Contractor is responsible to remove any waste generated by the work being done on the Site. The Contractor must dispose of the waste in line with the relevant local legislative requirements. The waste disposal route shall be documented and made available for Owner to review at any time and may be subject to Owner's prior approval.

Wastes (includes rinse from washing of equipment, PPE, tools, etc) are not to be poured into sinks, drains, toilets, or storm sewers, or onto the ground. Solid or liquid wastes that are hazardous or regulated in any way are not to be disposed of in general site waste receptacles.

Spills

The Contractor is responsible for the provision of adequate spill kits/protection and the clean up and disposal costs arising from such spills.

Emissions

The Contractor shall identify and quantify any emission sources associated with the Works. The control measures associated with these emission shall be subject to the approval of Owner's Emissions include but are not limited to noise, dust, fumes, vapours.

19. PENALTIES IN CASE OF NON-COMPLIANCE OF SAFETY/HEALTH/ENVIRONMENT NORMS, RULES & REGULATIONS

The contractor has to follow all norms, rules and regulations related to safety, health and environment, In case of non-compliance of any one of these norms, rules and regulations by contractor's employee, the contractor shall be held responsible. If any violation or non-fulfilment of these norms, rules and regulation is observed by the Company's authority during checking at any time, a penalty of Rs 2000/- shall be imposed on the contractor for each occasion of non-compliance to these rules and regulations by him or his employees. The decision of the Company's authority shall be final and binding on to the contractor in this regard. The amount of penalties so imposed shall be recovered from the next RA Bill of the work or any other dues payable to the contractor by the authority.

20. ARBITRATION

If any dispute or difference arises between the Parties inter alia in respect of the interpretation of this Agreement or of the rights or liabilities of either in respect of anything done or omitted or to be done or omitted hereunder, the Parties shall endeavour to settle such dispute amicably.

If not, such dispute or difference shall be referred for adjudication at Mumbai to a sole arbitrator to be appointed by Head[IP], Balmer Lawrie & Co Ltd.

The place of Arbitration shall be Mumbai, India. The arbitration proceedings shall be in the English language. Cost of Arbitration shall be equally shared between the Parties. It is expected that the arbitral award shall be a speaking award setting out reasons thereof. In making the award, the arbitrator(s) shall be bound by the intention of the Parties insofar as the same can be ascertained from this Agreement.

21. Control Regulations

Successful bidder warrants that all goods/materials covered by this order have been produced, sold, despatched, delivered and furnished in strict compliance with all applicable laws regulations, labour agreement, working conditions and technical codes and statutory requirements as applicable from time to time. All laws and regulations required to be incorporated in executing this tender are hereby deemed to be

incorporated by this reference. Owner can disown any responsibility for any irregularity or contravention of any of the statutory regulations in the manufacture or supply of goods covered in the order. The Bidder shall ensure compliance with the above and shall indemnify tenderer against any actions, damages, costs and expenses of any failure to comply as aforesaid.

22. Code of Conduct for Balmer Lawrie & Co. Suppliers / Contractors

This Code of Conduct defines the basic requirements placed on Balmer Lawrie & Co.'s suppliers of goods and services concerning their responsibilities towards their stakeholders and the environment. Balmer Lawrie & Co. reserves the right to reasonably change the requirements of this Code of Conduct due to changes of the Balmer Lawrie & Co. Compliance Program. In such event Balmer Lawrie & Co. expects the supplier to accept such reasonable changes.

The supplier declares herewith:

f **Legal compliance**

- o to comply with the laws of the applicable legal system(s).

f **Prohibition of corruption and bribery**

- o to tolerate no form of and not to engage in any form of corruption or bribery, including any payment or other form of benefit conferred on any government official for the purpose of influencing decision making in violation of law.

f **Respect for the basic human rights of employees**

- o to promote equal opportunities for and treatment of its employees irrespective of skin color, race, nationality, social background, disabilities, sexual orientation, political or religious conviction, sex or age;
- o to respect the personal dignity, privacy and rights of each individual;
- o to refuse to employ or make anyone work against his will;
- o to refuse to tolerate any unacceptable treatment of employees, such as mental cruelty, sexual harassment or discrimination;
- o to prohibit behavior including gestures, language and physical contact, that is sexual, coercive, threatening, abusive or exploitative;
- o to provide fair remuneration and to guarantee the applicable national statutory minimum wage;
- o to comply with the maximum number of working hours laid down in the applicable laws;
- o to recognize, as far as legally possible, the right of free association of employees and to neither favor nor discriminate against members of employee organizations or trade unions.

f **Prohibition of child labor**

- o to employ no workers under the age of 18;

f **Health and safety of employees**

- o to take responsibility for the health and safety of its employees;

- o to control hazards and take the best reasonably possible precautionary measures against accidents and occupational diseases;
- o to provide training and ensure that employees are educated in health and safety issues;
- o to set up or use a reasonable occupational health & safety management system;
- f **Environmental protection**
 - o to act in accordance with the applicable statutory and international standards regarding environmental protection;
 - o to minimize environmental pollution and make continuous improvements in environmental protection;
 - o to set up or use a reasonable environmental management system;
- f **Supply chain**
 - o to use reasonable efforts to promote among its suppliers compliance with this Code of Conduct;
 - o to comply with the principles of non discrimination with regard to supplier selection and treatment.

I/We accept all your terms and conditions as stated above.

For **BALMER LAWRIE & CO LTD**
INDUSTRIAL PACKAGING - SILVASSA

AUTHORIZED SIGNATORY

ANNEXURE-IV

(SAMPLE FORMAT. NOT TO BE FILLED IN. PRICE SHOULD BE QUOTED THROUGH ON LINE)

PRICE BID

S.No.	Description	A	B	C[AXB]
		QTY / NO.	RATE/ RS.(LUMP SUM)	VALUE RS.
A	MOTORIZED VERTICAL COIL LIFTER	1 (ONE)		
B	GST	%		
C	TOAL PRICE(A+B)			
D	NET LANDED [C-B]			

**NB : PRICE SHOULD BE INCLUSIVE OF CHARGES OF DESIGN / SUPPLY/ FREIGHT/
INSTALLATION & COMMISSIONING.**

I / We have studied the Tender Documents carefully and have quoted our lowest rates, in
accordance with the **Terms and Conditions** as laid down in the Tender Documents.

Company Seal	Signature	
	Name	
	Designation	
	Company	
	Date	

Annexure-V

(To be provided by successful bidder only)

**Proforma of the Bank Guarantee
(Security Deposit)**

**Balmer Lawrie & Co. Ltd.
5, J N Heredia Marg,
Ballard Estate,
Mumbai – 400 001.**

Dear Sir,

That Messrs. /Mr. _____ (set out full name and a Bidder and constitution of the Contractor) (hereinafter referred to as "the Contractor") filed their / his / its quotation against your Tender being Tender No. _____ dated _____(hereinafter referred to as "the said Tender") for the Supply of "Road Repairing Job" and in pursuance thereto an Order being No. _____ dated (hereinafter referred to as "the Order") was issued by you to the Contractor.

The conditions of the said Tender, inter alia, require that the Contractor shall pay a sum of Rs. (Rupees only) as full security deposit (hereinafter referred to as "the security deposit") in the form therein mentioned. The form of payment of security deposit includes a guarantee to be executed by a Scheduled Indian Bank.

The said Messrs. / Mr. _____ (set out full name of the Contractor) have / has approached us and at their / his / its request and in consideration of the premises. We _____ (set out full name of the Bank) having our office, inter alia at _____ (state the address of the Bank) has agreed to give such guarantee in the manner following:

1. We, _____ (set out full name of the Bank), hereby undertake and agree with you if default is made by Messrs. / Mr. _____ (set out full name of the Contractor), in performing any of the terms and conditions of the Tender and / or Order or in payment of the security deposit or any other or in payment of money payable to you, We, _____ (set out full name of the Bank) shall merely on demand from you without demur or protest shall pay you the said amount Rs. 000.00 (only) or such portion thereof not exceeding the said sum as you may demand from time to time.

2. We, _____ (set out full name of the Bank), further agree with you that you shall have the fullest liberty to without our consent and without affecting in any manner our obligations hereunder to adopt any mode for realization of your dues from the Contractor and/or to vary any of the Terms and Conditions of your Contract with the said Messrs. / Mr. _____ (set out full name of the contractor) or to extend time of performance by Contractor from time to time or to postpone for any time or from time to time any of the powers exercisable by you against Contractor and to forbear or enforce any of the terms and conditions relating to the Contract and We, _____ (set out full name of the Bank) shall not be relieved from our liability by reason of any such variation, or any indulgence to be given by you to the Contractor or by any such matter or thing whatsoever which under the law relating to sureties would but for this provision have effect of so releasing us.

3. Your right to recover the said sum of Rs. 000.00 (Rupees only) from us in the manner aforesaid will not be affected or suspended by reason of the fact that any dispute or disputes is / are pending before any Officer, tribunal, court or any other authority or authorities.
4. The guarantee herein contained shall not be determined or affect by liquidation or winding up, dissolution or change of constitution or insolvency of the said Messrs. / Mr. _____ (set out the full name of the Contractors), but shall in al respect, and for all purposes be binding and operative until payment of all the money due to you in respect of such liabilities is paid.
5. Our liability under this guarantee is restricted to Rs. 00.00 (Rupees only)
6. Our guarantee shall remain in force and effect until _____ (set out the date of Expiry) and unless a claim or demand in writing is made against us under this guarantee before the expiry of six months from the aforesaid date i.e. _____ (set out last date of Claim period), the said Guarantee all your rights under this guarantee shall be forfeited and We, _____ (set out full name of the Bank) shall be relieved and discharged from all liabilities there by.
7. We, _____ (set out full name of the Bank) undertake not to revoke this Guarantee during its currency except with your previous consent in writing.
8. We, _____ (set out full name of the Bank) have power to issue this Guarantee in your favor under our Memorandum and Articles of Association and the undersigned has full power to execute / sign this Guarantee under the Power of the Attorney dated the _____ day of _____ Two Thousand _____ granted by the Bank.

Yours faithfully,

Dated:

ANNEXURE-VI

CONDITIONS FOR ONLINE BID SUBMISSION

Procedure For Bid Submission

The bidder shall submit his response through bid submission to the tender on eProcurement platform at <https://balmerlawrie.eproc.in> by following the procedure given in the Catalogue.

Registration with eProcurement platform:

For registration and online bid submission bidders may contact HELP DESK of M/s C1 India Pvt., Ltd.

The contact persons are :

C1 India Pvt.Ltd.
603,Coral Classic,20th Road,
Near Ambedkar Park, Chembur
Mumbai-400 071

1. Mr.Tuhin Ghosh,Mob.08981165071
Email – tuhin.ghosh@c1india.com
2. Mr. Tirtha Das, Mob 9163254290
Email - tirtha.das@c1india.com
3. Mr. Ravi Gaiwal, Tel +9619379192
Email - ravi.gaiwal@c1india.com
4. Mr. Siva Kumar (Chennai)
Mob.- 9042773377
E-mail-siva.kumar@c1india.com

Digital Certificate authentication:

The bidder shall authenticate the bid with his Digital Certificate (Class II) for submitting the bid electronically on eProcurement platform and the bids not authenticated by digital certificate of the bidder will not be accepted on the eProcurement platform.

All the bidders who do not have Digital Certificates need to obtain Digital Certificate. They may contact Help Desk of C1 India Pvt Ltd.

Submission of Hard copies:

After submission of bid online, the bidders are requested to submit the demand drafts / Bank Guarantee towards tender fees and / EMD along with other documents as required, to the Tender Inviting Authority before opening of Techno-commercial / Unpriced bid at our IP-Silvassa Office. The bidder shall furnish the Demand Draft and other documents either in person or through courier or by post and the receipt of the same within the stipulated time shall be the responsibility of bidder. BL shall not take any responsibility for any delay or non-receipt of said documents. If any of the documents furnished by the bidder is found to be false / fabricated, the bidder is liable for black listing, forfeiture of the EMD, cancellation of work and criminal prosecution.

The bidder is requested to get a confirmed acknowledgement from the Tender Inviting Authority as proof of submission of hardcopies.

Corrigendum to tender:

The bidder has to keep track of any changes by viewing the addendum / Corrigendum's issued by the Tender Inviting Authority on time-to- time basis in the E-Procurement platform. The Company calling for tenders shall not be responsible for any claims/problems arising out of this.

Bid Submission Acknowledgement:

The user should complete all the processes and steps required for bid submission. The successful bid submission can be ascertained once acknowledgement is given by the system through bid submission number after completing all the processes and steps. Tender Inviting Authority and C1 India Pvt. Ltd. will not be responsible for incomplete bid submission by users. Users may also note that the incomplete bids will not be saved by the system and are not available for the Tender Inviting Authority for processing .

Before uploading scanned documents, the bidders shall sign on all the statements, documents, certificates uploaded by him, owning responsibility for their correctness / authenticity.

Disclaimer Clause:

The Company (Balmer Lawrie & Co. Ltd.) nor the service provider (C1 India Pvt. Ltd.) is responsible for any failure of submission of bids due to failure of internet or other connectivity problems or reasons thereof.

Annexure-VII

A. GST Compliances

- [1] Vendor to comply with all requirements under GST and provide their GST Registration details as per Annexure-VIII attached
- [2] Vendor to issue a valid invoice with correct and complete disclosures as required under GST invoice rules and payments shall be processed only post receipt of correct invoice from the vendor
- [3] Vendor has to provide clear indication of place of supply [Invoicing location] related to place of supplies [BL location].
- [4] Vendors are required to raise invoice as per the GST tax structure.
- [5] Vendors to ensure that all invoices submitted are compliant with GST Laws. Any discrepancies in the Invoice which results in tax credit loss to Balmer Lawrie will be recovered from vendors.
- [6] In case of advance payment against goods/services, vendor to ensure payment of tax as per GST Laws.
- [7] Balmer Lawrie will keep a watch on compliance rating of their vendors as per the GST portal. If at any time such rating falls below prescribed criteria, Balmer Lawrie will have right to terminate the services without any prior notice to vendor.

Company Seal	Signature	
	Name	
	Designation	
	Company	
	Date	

ANNEXURE-VIII

B. DETAILS OF VENDOR

1	Name of the Vendor	
2	Address	
3	Postal Code	
4	State	
5	Country	
6	Telephone No.	
7	Mobile No.	
8	Fax No.	
9	Email ID	
10	Contact Person	
11	Bank Name	
12	Street	
13	City	
14	Branch Name	
15	IFSC Code	
16	MICR Code	
17	Account Number	
18	Minority Indicator	
19	GSTIN Registration Number	
20	HSN /SAC Code for Supply/Service	
21	GST rate (in %) applicable for Supply/Service to be provided.	
22	Composition Scheme Applicable	Yes / No
23	Proof of GSTIN Registration No. per state [From GSTN website]	
24	Vendor's GSP name [GST Suvidha Provider's]	
25	Exemption No.	
26	Exemption Percentage	
27	Exemption Reason	
28	Exempt From	
29	Exempt To	